

**Isolation of amylase producing bacteria from soil and  
identification by 16S rRNA gene sequencing and  
characterization of amylase**



**A Dissertation Submitted to the Department of Mathematics and Natural  
Sciences, BRAC University in Partial Fulfillment of the Requirement for the  
Degree of Bachelor of Science in Microbiology**

**Department of Mathematics and Natural Sciences  
BRAC University**

**Submitted by:  
Tasnia Islam  
Student ID: 12126005  
June 2016**

*Dedicated to*

*My*

*greatest strength*

*My Parents*

ScholarlyPen

## Declaration by the Researcher

This is to declare that the research work embodying the results reported in this thesis entitled **“Isolation of amylase producing bacteria from soil and identification by 16S rRNA gene sequencing and characterization of amylase”** has been carried out by the undersigned, under the joint supervision of Trosporsha Tasnim Khan, Lecturer, Microbiology program, Department of Mathematics and Natural Sciences, BRAC University, and Dr. Mahboob Hossain, Associate Professor, Microbiology Program, Department of Mathematics and Natural Sciences, BRAC University. It is further declared that the research work presented here is original and submitted in the partial fulfillment for the degree of Bachelors of Science in Microbiology, BRAC University, Dhaka and has not been submitted anywhere else for a degree or diploma.

\_\_\_\_\_  
**Tasnia Islam**

(Candidate)

Certified

\_\_\_\_\_  
**Trosporsha Tasnim Khan**

Supervisor

Lecturer,

Microbiology Program,

Department of Mathematics and Natural Sciences,

BRAC University

\_\_\_\_\_  
**Dr. Mahboob Hossain**

Co-Supervisor

Associate Professor,

Microbiology Program, Department of Mathematics

and Natural Sciences,

BRAC University

# *Acknowledgement*

First and foremost, I want to express gratitude to Almighty Allah for blessing me with good health and bestowing upon me the patience and determination to reach my goal.

I wish to offer my sincerest thanks to Prof. A. A. Ziauddin Ahmad, Chairperson, Department of Mathematics and Natural Sciences, BRAC University, for his kind permission to carry out my thesis in the Microbiology Laboratory of BRAC University.

I would like to thank Professor Naiyyum Choudhury, Chairperson, Bangladesh Atomic Energy Regulatory Authority (BAERA) and former Coordinator of Biotechnology and Microbiology Program, Department of Mathematics and Natural Sciences, BRAC University, for inspiring and motivating me to work on this topic of research.

I acknowledge my esteem to my co-supervisor, Dr. Mahboob Hossain, Associate Professor, Microbiology Program, Department of Mathematics and Natural Sciences, BRAC University, for his keen interest, constant guidance and encouragement to my work.

My heart-felt gratitude goes to my supervisor Trosorsha Tasnim Khan, Lecturer, Department of Mathematics and Natural Sciences, BRAC University, for her constant inspiration, constructive criticism, supervision and valuable suggestions without which this thesis would not have been completed.

I would like to thank all the teaching assistants along with the laboratory officers, Asma Binte Afzal and Shamim Akhter Chowdhury who co-operated with me and assisted me throughout the study.

I am thankful to Invent Technologies Ltd. and 1<sup>st</sup> BASE Laboratories (Malaysia) for their excellent services and kind contribution towards the study.

My deepest appreciation goes to my thesis partners, Sazzad Khan for his help and pleasant company and Faria Mahjabeen who supported me immensely during my time of crisis. I am also thankful to all my friends for their interest, constant support and positivity towards my work.

Finally, I owe my earnest gratitude and appreciation to my parents and grandmother, who shouldered all my responsibilities for such a prolonged period with smiling faces, who believed in me and allowed me to carry out my work undisturbed. **Tasnia Islam**

ScholarlyPen

## Table of Contents

Contents	Page no.
Declaration by the Researcher	i
Acknowledgement	ii
Table of Contents	iv
List of Figures	viii
List of Tables	x
List of Abbreviations	xi
Abstract	xiii

Contents	Page no.
<b>Chapter 1: Introduction</b>	1
<b>Overview</b>	2
<b>Literature review</b>	3
1.1. Enzyme	3
1.2. History of enzyme discovery	3
1.3. Structure of an enzyme	3
1.4. Classes and functions of enzymes	5
1.5. Amylase	6
1.6. History of amylase	7
1.7. Types of amylase	7
i. Endo-acting or endo-hydrolases	8
ii. Exo-amylase or exo-hyrolases	8
1.8. Structure of amylase	8
1.9. Starch	9
1.10. Structure of starch	9
1.11. Microbial amylase	10
1.12. Use of microbial amylase in industries	11
<b>Aim of the study</b>	13
<b>Chapter 2: Materials and Methods</b>	14
2.1. Duration of study	15
2.2. Place of study	15

2.3. Handling of laboratory apparatus and glassware	15
2.4. Solutions and reagents	15
2.5. Use of media	15
2.6. Isolation of bacterial cultures	16
2.6.1. Collection of soil sample	16
2.6.2. Screening and selecting potent amylase producing bacteria using starch hydrolysis test	16
2.7. Collection of crude amylase enzyme from bacteria	16
2.7.1. Inoculum preparation	17
2.7.2. Fermentation	17
2.7.3. Separation of crude enzyme from culture media	17
2.8. Enzyme assay to determine amylase activity	17
2.8.1. Enzyme assay	17
2.8.2. Formation of glucose standard curve	18
2.9. Determination of specific amylase activity	19
2.9.1. Extracellular protein concentration	19
2.9.2. Formation of protein standard curve	20
2.10. Phenotypic identification of bacterial strain	21
2.10.1. Microscopic observation	21
2.10.1.1. Gram staining	21
2.10.1.2. Spore staining	21
2.10.2. Cultural characterization	21
2.10.3. Biochemical characterization	22
i. Catalase test	22
ii. Oxidase test	22
iii. MRVP test	22
a) VP test	22
b) MR test	23
iv. TSI test	22
v. Simmon's citrate test	23

vi. MIU test	23
vii. Gelatin hydrolysis	24
viii. Nitrate reduction test	24
ix. MSA plate test	24
x. Casein hydrolysis test	24
xi. Hemolysis of blood	25
xii. Cellulose degradation	25
xiii. Growth on anaerobic condition	25
xiv. Growth at 45°C and 65°C	26
xv. Growth in 7% NaCl	26
xvi. Fermentation of sugar: Xylose, Maltose, Sucrose, Glycerol and Fructose	26
2.11. Genotypic identification of bacterial strain	26
2.11.1. DNA extraction	26
2.11.2. Amplification of extracted DNA using Polymerase Chain Reaction	27
2.11.3. Detection of DNA using agarose gel electrophoresis	28
2.11.4. Purification of DNA	28
2.11.5. Measurement of DNA concentration and purity	29
2.11.6. DNA sequencing	29
2.11.7. Bioinformatics analysis	29
2.12. Characterization of amylase enzyme	29
2.12.1. Determination of optimum temperature	29
2.12.2. Determination of optimum pH	30
2.13. Culture preservation	30
<b>Chapter 3: Results</b>	31
3.1. Isolation and selection of amylase producing bacteria from soil	32
3.2. Enzyme assay to select the highest amylase producing bacteria	35
3.3. Determination of specific activity of amylase enzyme	36
3.4. Identification of selected amylase producing bacteria	37

3.4.1. Gram staining	37
3.4.2. Spore staining	37
<hr/>	
3.5. Colony morphology	38
3.6. Biochemical tests	39
3.7. Amplification and detection of 16s rRNA of the bacterial strain	42
3.8. DNA sequencing	43
3.9. Bioinformatics analysis to identify the bacteria	43
3.10. Characterization of amylase enzyme	47
3.10.1. Effect of temperature	47
3.10.2. Effect of pH	47
<b>Chapter 4: Discussion</b>	<b>49</b>
<b>References</b>	<b>57</b>
<b>Appendix-I: Media Compositions</b>	<b>61</b>
<b>Appendix-II: Reagents and buffers</b>	<b>65</b>
<b>Appendix-III: Instruments</b>	<b>69</b>

## List of Figures

Figure	Page No.
<b>Figure 1.1:</b> Typical protein structure: two amino acids joined by a peptide bond	4
<b>Figure 1.2:</b> Holoenzymes attached to apoenzymes and different types of cofactors	4
<b>Figure 1.3:</b> Breakdown of starch by $\alpha$ -Amylase	7
<b>Figure 1.4:</b> 3D structure of $\alpha$ -amylase	8
<b>Figure 1.5:</b> Structure of amylose (left) and amylopectin (right)	10
<b>Figure 3.1:</b> Percentages of different types of bacteria obtained from starch agar plates	32
<b>Figure 3.2:</b> Comparison among the average ratio of clear zones of the amylase producing bacteria on starch agar plates	34
<b>Figure 3.3:</b> Zone of clearance produced by isolate 14 (left) and isolate 28 (right) on starch agar media	34
<b>Figure 3.4:</b> Glucose standard curve	35
<b>Figure 3.5:</b> Enzyme activities of isolates 14 and 28	35
<b>Figure 3.6:</b> Standard protein estimation curve	36
<b>Figure 3.7:</b> Specific enzyme activities of isolates 14 and 28	36
<b>Figure 3.8:</b> Appearance of Gram positive colony 14 under the microscope	37
<b>Figure 3.9:</b> Appearance of isolate 14 after spore staining under the microscope. The spores are stained green whereas the bacterial cells are stained red.	37
<b>Figure 3.10:</b> Appearance of isolate 14 on nutrient agar medium	38
<b>Figure 3.11:</b> Results of some of the biochemical tests performed	41
<b>Figure 3.12:</b> Visible DNA bands over UV illuminator on 1% agarose gel after electrophoresis. It can be seen that the 16S rDNA bands of isolate 14 which migrated along the lanes of wells 3 and 4 are slightly lower than 1,650 bp when compared to the ladder which migrated along the lane of well 5. Lane 1 indicates the DNA and of positive control and lane 4 shows that no band can be seen for the negative control.	42
<b>Figure 3.13:</b> Molecular Phylogenetic analysis by Maximum Likelihood method. The query sequence in this tree is subjected as 'Emboss 001'. It can be observed that the query sequence shares the same node with <i>Bacillus cereus</i>	46

---

ATCC 14579 16S ribosomal (rrna) RNA gene complete sequence and the bootstrap value is 70. This confirms that isolate 14 is a strain of *Bacillus cereus*

**Figure 3.14:** Effect of temperature on the activity of crude amylase of isolate 14 47

**Figure 3.15:** Effect of pH on the activity of crude amylase of isolate 14 48

---

ScholarlyPen

## List of Tables

Table	Page no.
<b>Table 1.1:</b> Classes of enzymes with their functions	5
<b>Table 1.2:</b> Uses of amylase in various sectors of industry	12
<b>Table 2.1:</b> Amount of components used to formulate the glucose standard curve	19
<b>Table 2.2:</b> Amount of components used to formulate the protein standard curve	20
<b>Table 2.3:</b> Primers used in the PCR reaction	27
<b>Table 2.4:</b> Reaction set up for PCR carried out for 50 µl reaction volume	27
<b>Table 2.5:</b> PCR reaction condition	28
<b>Table 3.1:</b> Average ratio of clear zones of selected colonies from nutrient agar media on starch agar media	33
<b>Table 3.2:</b> Colony morphology of isolate 14	38
<b>Table 3.3:</b> Biochemical tests performed and results obtained for isolate 14	40
<b>Table 3.4:</b> Trimmed and corrected DNA sequence of 16S rRNA gene sequence of isolate 14 (FASTA format)	44
<b>Table 3.5:</b> Top 10 similar sequences compared to the 16S rRNA gene sequence of isolate 14 acquired from NCBI nucleotide BLAST	45

## List of Abbreviations

- g : Gram
- ml : Millilitre
- $\mu$ l : Microlitre
- g/L : Gram per litre
- mg/ml : Milligram per millilitre
- ng/ $\mu$ l : Nanogram per microlitre
- *et al* : And others
- n.d : No date
- pH : Negative logarithm of Hydrogen ion concentration
- rpm : Revolutions per minute
- V : Volt
- U/ml : Units per millilitre
- U/mg : Units per milligram
- RNA : Ribonucleic acid
- DNA : Deoxyribonucleic acid
- bp : Base pair
- kb : Kilobase pair
- NCBI : National Centre for Biotechnology Information
- BLAST : Basic Local Alignment Search Tool
- $^{\circ}$ C : Degree Celsius
- $(\text{NH}_4)_2\text{SO}_4$  : Ammonium sulphate
- $\text{MgSO}_4 \cdot 7\text{H}_2\text{O}$  : Magnesium sulphate heptahydrate
- $\text{KH}_2\text{PO}_4$  : Monopotassium phosphate
- $\text{CaCl}_2 \cdot 2\text{H}_2\text{O}$  : Calcium chloride dihydrate
- $\text{NaH}_2\text{PO}_4$  : Monosodium phosphate
- $\text{Na}_2\text{HPO}_4$  : Disodium phosphate
- NaOH : Sodium hydroxide
- HCl : Hydrochloric acid
- NaCl : Sodium chloride
- DNS : 3,5- Dinitrosalicylic acid
- nm : Nanometre

□ BSA	:	Bovine serum albumin
□ Alk. CuSO <sub>4</sub>	:	Alkaline copper sulphate
□ Psi	:	Per square inch
□ HEPA	:	High efficiency particulate air
□ v/v	:	Volume/volume
□ dNTP	:	Deoxynucleotide
□ M	:	Molar
□ mM	:	Millimolar
□ N	:	Normal
□ EDTA	:	Ethylenediaminetetraacetic acid
□ UV	:	Ultra violet

ScholarlyPen

## Abstract

The use of amylase enzyme has been extensive in different industrial sectors for quite a long time because of its multifarious applications. Unfortunately, Bangladesh lacks any local production of amylase although many industries are highly dependent on the enzyme. In this study, bacteria from soil sample were primarily screened on starch agar medium to identify any amylase producer through the detection of a clear zone around the bacterial colony after adding Gram's iodine. Out of 48 isolates, 17 were observed to produce amylase but only two isolates, 14 and 28 were selected based on the highest clear zone ratio. The two isolates were further screened by monitoring their enzyme activities using the DNS method and specific enzyme activities using Folin-Lowry method. Since isolate 14 showed a higher enzyme activity (0.123 U/ml) and specific enzyme activity (0.173 U/mg), it was chosen as the bacteria to be worked with. Gram staining and spore staining revealed that this isolate is Gram positive, rod shaped, arranged singly and in chains and forms endospores. Colony morphology and biochemical profile were also conducted in order to identify the bacteria presumptively. Finally, genotypic identification was performed via the 16S rRNA gene sequencing. The bacterial DNA was extracted and its 16S rRNA gene was amplified via Polymerase Chain Reaction using 27F and 1492R universal primers. The DNA containing the gene was observed to be about 1,650 bp in length. Sanger sequencing method was used to sequence the DNA which revealed that it had a length of 1,436 bp. Furthermore, NCBI nucleotide BLAST website was used to align this sequence with the sequences of other bacteria in the database through which it was determined that isolate 14 belongs to the genus *Bacillus*. A phylogenetic tree was also constructed to determine the species of isolate 14 which revealed that isolate 14 is a strain of *Bacillus cereus*. Further investigation was carried out to characterize the amylase enzyme produced by this bacterial isolate. It was observed that the optimum temperature of the enzyme is 75°C while the optimum pH is 7. This indicated that the enzyme requires a moderately high temperature and neutral pH to show greatest activity.

## Chapter 1

# INTRODUCTION

### Overview

Amylase is an enzyme that hydrolyses starch into its monomeric compounds, the smallest being glucose. The glycosidic bonds that hold the monomers together are broken down by the enzyme. This is a very common and essential reaction that takes place within various living organisms in order to generate or store energy. Hence, amylase is a very prevalent enzyme produced biologically by various kinds of living beings. This includes plants, animals, humans and micro organisms.

There have been great advances in the use of amylase in industrial sectors as well. A large portion of the enzyme market share is owned by amylase (Gupta *et al.*, 2003). A wide range of industries such as food industries, garments, textiles and beverage industries along with medicinal and clinical chemistry use amylase to manufacture their products. This requires a constant production of amylase enzyme. Extraction of this huge quantity of amylase directly from nature is not feasible and hence various methods are being constantly established to develop the mass production of commercial amylase (Dash *et al.*, 2015).

Among the various types of amylase, the microbial amylase meets the industrial demands (Akcan *et al.*, 2011). Quite a large variety of micro organisms have been identified and chosen as the source of amylase production because of the availability and simplicity of the ways in which they yield amylase. Fungal amylases are used worldwide along with different strains of bacteria. Each strain of bacteria requires specific growth conditions and nutrients to produce amylase. Soil is a primary source of these bacteria which can be isolated and commercially grown in large numbers

to produce a vast amount of amylase. In order to provide this, industries use fermentation shake flasks to grow bacteria (Dash *et al.*, 2015).

In addition, the amylases that are extracted require optimum conditions to show greatest activity. This includes parameters such as temperature and pH (Sivaramakrishnan *et al.*, 2006). For this reason, it is important to find out the optimum conditions for amylase activity through research before it can be used for industrial purposes.

## Literature review

### 1.1. Enzyme

The term enzyme is a very familiar word to many. As defined, enzymes are biological compounds that speed up biochemical and biological reactions. Their role is to act as chemical catalysts which accelerate the time of these reactions both internal and external to an organism's cell (Gurung *et al.*, 2013). Hence, the term 'biocatalyst' has also been coined to define an enzyme. Without enzymes, it would be difficult to continue life since a huge number of biochemical reactions are required for an organism to function quickly and effectively. For this reason, enzymes are extremely important and valuable in order for an organism to live.

### 1.2. History of enzyme discovery

The use of enzymes has been evident among the human civilization for centuries. For instance, Egyptians used enzymes to preserve food and beverages. Moreover, the process of cheese making included the use of enzymes from as early as 400 BC (Gurung *et al.*, 2013). However, the term 'enzyme' was first introduced in 1877 by Wilhelm Friedrich Kuhne who was a professor of physiology at the University of Heidelberg. He was the first person to observe the scientific terminology of the protein molecule (Gurung *et al.*, 2013). On the other hand, their catalytic action was first studied by the Swedish chemist Jon Jakob Berzelius in 1835. James B. Sumner of Cornell University, on the other hand, first isolated pure form of enzyme in 1926, which earned him a Nobel Prize in 1947 (Worthington Biochemical Corporation, 1972).

### 1.3. Structure of an enzyme

Enzymes are globular folded protein arranged in a three dimensional structure (Mojsov, 2012). The molecular weight ranges from approximately 10,000 to up to millions (Koshland, 1963). They are made up of chains of amino acids linked with peptide bonds (Worthington Biochemical Corporation, 1972). Furthermore, enzymes are specific molecules. The specificity arises due to the selective binding site each type of enzyme possesses for its respective substrate. The substrate attaches to the binding site of the enzyme, which is known as the 'active site'. Here, various chemical bonds are broken and formed in the substrate, converting it into a product/s.

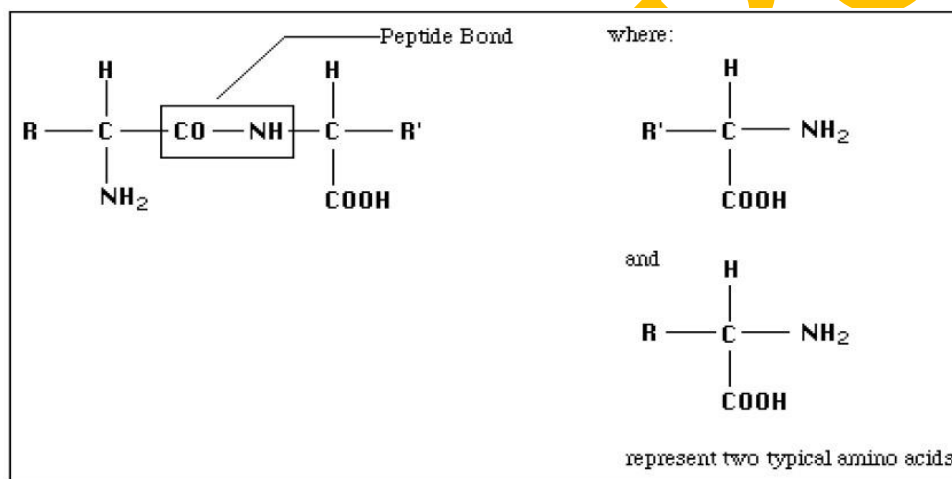

**Figure 1.1: Typical protein structure: two amino acids joined by a peptide bond (Worthington Biochemical Corporation, 1972)**

Various enzymes require additional components to function which are called 'co-factors'. They are essential in many catalytic steps or during conformational changes of substrates. These additional components include different metal ions, prosthetic groups and chemical groups called co-enzymes which are very tightly attached to the enzyme (Overington *et al.*, 2006). So, an enzyme is made up of a protein portion called the apoenzyme attached to the co-factor called the co-enzyme which makes an entire molecule called the holoenzyme (Worthington Biochemical Corporation, 1972). Besides, different enzymes have different optimal conditions of temperature and pH for its maximum level of activity.

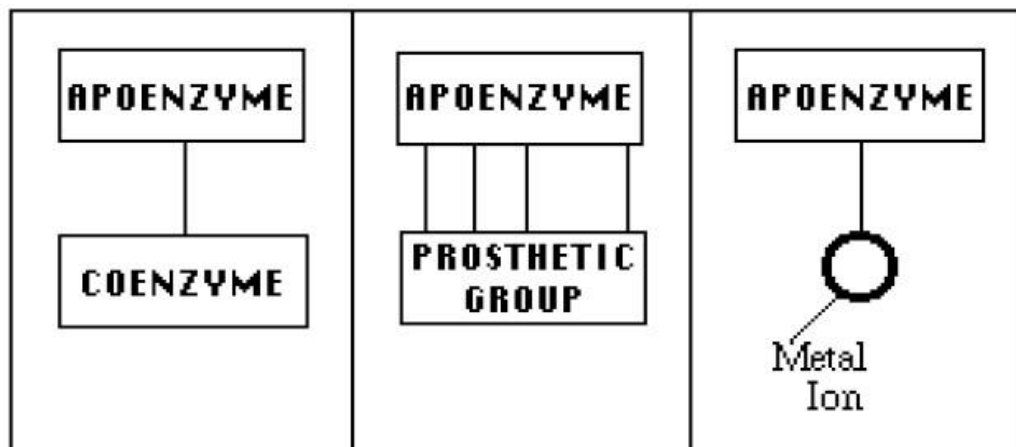

**Figure 1.2: Holoenzymes attached to apoenzymes and different types of cofactors (Worthington Biochemical Corporation, 1972)**

#### 1.4. Classes and functions of enzymes

There are quite a variety of functions that enzymes perform. They are mostly responsible for the chemical interconversion needed for an organism to live (Gurung *et al.*, 2013). For instance, a huge number of biochemical reactions, known as metabolism, take place in a living organism. These continuous physical and chemical changes require catalysts to speed them up (Worthington Biochemical Corporation, 1972). About 4000 biochemical reactions are catalyzed by enzymes (Gurung *et al.*, 2013). The functions of enzymes ranges from digestion of food, replacement of old tissue, build up of new tissue to new DNA synthesis (Gurung *et al.*, 2013; Worthington Biochemical Corporation, 1972).

There are various categories of enzymes found in nature. Each enzyme has a different mode of function on its specific substrate. Some enzymes break down polymeric compounds into its constituent monomers, whereas others do the reverse. In addition, some enzymes transform the conformational structure of a molecule into a different form. Depending on the type of function of an enzyme, they are given selective names. According to the Enzyme Commission, the enzymes are categorized into 6 different types (Gurung *et al.*, 2013) as illustrated in Table 1.1.

**Table 1.1: Classes of enzymes with their functions (Gurung *et al.*, 2013)**

<b>Enzyme commission number</b>	<b>Class of enzyme</b>	<b>Function</b>	<b>Example</b>
EC1	Oxidoreductases	Transfer of electrons between molecules is catalyzed by these enzymes. In biological systems, the transfer of hydrogen molecules takes place. The enzymes which do these are typically called dehydrogenases.	Alcohol dehydrogenase
EC2	Transferases	Different types of atoms are transferred between different molecules by these enzymes.	Aminotransferase
EC3	Hydrolases	This class of enzymes breaks down molecules with the help of water.	Amylase
EC4	Lyases	Lyases remove groups to form double bonds or add groups to double bonds in substrates.	Pectate lyase
EC5	Isomerases	These enzymes cause structural transformation of the same molecule by transferring groups from one position to another.	Mutase
EC6	Ligases	Molecules are joined together via covalent bonds by these enzymes. These reactions require energy input in the form of co-factors called ATP.	DNA ligase

Enzymes have been collected from natural sources for the use of industrial purposes for a long time. Different enzymes have been extracted and produced in mass amounts in industrial fermenters for the manufacture, break down and conversion processes of different compounds. Among the many types of enzymes used, the amylase enzyme is a very popular one.

## 1.5. Amylase

The enzyme amylase breaks down carbohydrate molecules into smaller products. Their main substrate is starch which is broken down into their smaller components such as dextrin, maltose, maltotriose, and glucose. The enzyme basically hydrolyses the  $\alpha$ -1, 4 - glycosidic bonds that hold the glucose units together (Gurung *et al.*, 2013). Hence, amylase is also addressed as ‘glycoside hydrolases’ (Kaur *et al.*, 2012). Apart from starch hydrolysis, other forms of amylase known as transglycosylating enzymes, cause starch modification (Sivaramakrishnan *et al.*, 2006).

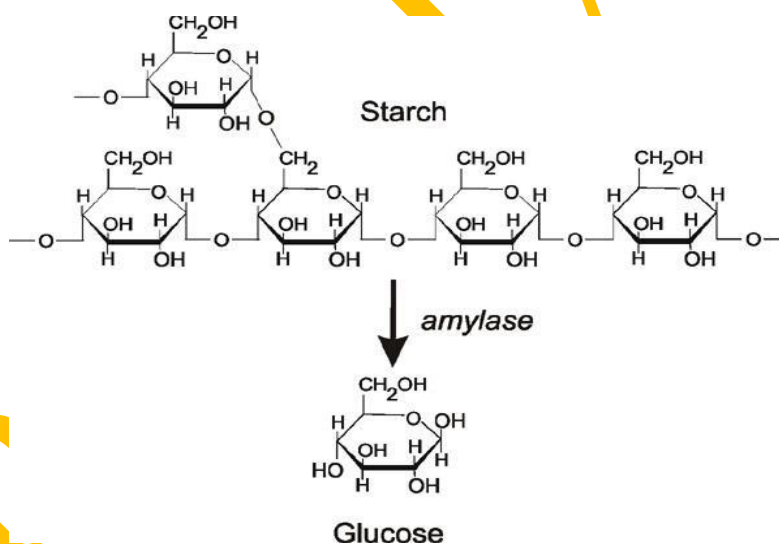

Figure 1.3: Breakdown of starch by  $\alpha$ -Amylase (Held, 2012)

## 1.6. History of amylase

In 1814, the first starch degrading enzyme was discovered by Kirchoff. In one of his experiments, he observed that a paste made of water, starch and malt was converted into sweet syrup by the action gluten present in the paste. From this observation, he first discovered the presence of the enzyme amylase (Roy *et al.*, n.d., para. 3). After several reports being established on the enzyme following the discovery, classification of amylase was suggested by the Ohlsson by observing the

different anomeric forms of sugars being produced from enzymatic reactions in malt (Gupta *et al.*, 2003).

### 1.7. Types of amylase

Amylase comes in two different types, endoacting or endohydrolases and exo-amylase or exohydrolases (Parmer and Panday, 2012):

#### i. Endo-acting or endo-hydrolases:

This type of amylase splits the interior glycosidic bonds of the amylose or amylopectin chain present in starch (El-Fallal *et al.*, 2012). Hence, the name endoenzyme has been given to them. This type of amylase breaks down glycosidic bonds in a random manner (Gupta *et al.*, 2003). A well known endoamylase is the  $\alpha$ -amylase. Most  $\alpha$ -amylase enzymes require calcium ions for their activity. For this reason, they are called metalloenzymes. This enzyme produces oligosaccharides as end products, which have a branched structure of varying lengths along with  $\alpha$ - configurations and  $\alpha$  – limit dextrins (El-Fallal *et al.*, 2012).

#### ii. Exo-amylase or exo-hydrolases:

This type of amylase breaks down starch, resulting in small end products (El-Fall *et al.*, 2012). The  $\alpha$ -1, 4- glycosidic bonds are exclusively broken down by the exo-amylase known as  $\beta$ - amylase (El-Fall *et al.*, 2012). Also known as 1, 4- $\alpha$ -D- glucan maltohydrolase,  $\beta$ -amylase works from the non reducing end of the molecule. Two glucose units (maltose) are split at a time as  $\beta$ - amylase cleaves the second  $\alpha$ -1, 4- glycosidic bond of the molecule (Gurung *et al.*, 2013). Other exo amylases cleave both  $\alpha$ -1, 4 and  $\alpha$ -1, 6-glycosidic bonds.  $\gamma$ - amylase, or alternatively called glucoamylase or amyloglucosidase, is an example of such an amylase (Parmar and Pandey, 2012).

## 1.8. Structure of amylase

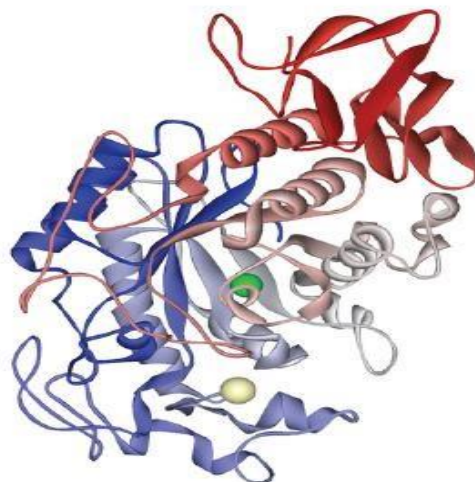

**Figure 1.4: 3D structure of  $\alpha$ -amylase (Roy *et al.*, n.d., para. 5)**

The structure given in Figure 1.4 is a three dimensional (3D) ribbon structure of  $\alpha$ -amylase, one of the most popular amylases found in different organisms. The protein is made up of 496 amino acid arranged in alpha helices and beta sheets. The structure also contains 170 water molecules, one calcium ion and one chloride ion. Three water molecules and one of each amino acids asparagine, aspartate, arginine and histamine are bound to the calcium ion. Calcium is needed for the enzyme to function. Also, two arginines, one asparagine and one water molecule is attached to the chloride ion (Roy *et al.*, n.d., para. 5).

## 1.9. Starch

The main substrate that amylase works on is starch. It is a complex polysaccharide containing  $\alpha$ 1, 4-glycosidic bonds between its glucose monomers. This glycosidic bond is stable at high pH but breaks down at low pH (El-Fallal *et al.*, 2012). Starch is a carbohydrate and is a very common and useful source of energy for plants, animals, micro organisms and humans (El-Fallal *et al.*, 2012). Starch is naturally produced mostly by higher plants as a result of photosynthesis, hence it is considered as a renewable raw material (Leszczynski, 2004). During dark periods, starch is stored in the plastids as a source of respiration. Some algae also produce starch called phytoglycogen (El-Fallal *et al.*, 2012).

Starch has been widely used in industries in order to provide textural properties to many foods. It has been used as thickeners, colloidal stabilizers, gelling and bulking agents and water retention agents in food and many industrial processes (Mojsov, 2012).

## 1.10. Structure of starch

Two different glucose polymers make up a starch molecule. These are amylose and amylopectin. Amylose is made up of around 6,000 glucose molecules arranged in a linear fashion via  $\alpha$ -1, 4-glycosidic bonds. Around 20 to 30% of the starch molecule consists of amylose (El-Fallal *et al.*, 2012). Amylopectin on the other hand, is a branched molecule. It consists of a linear structure made up of  $\alpha$ -1, 4-glycosidic bonds which is similar to amylose, but the branches are formed by  $\alpha$ -1, 6-glycosidic bonds. Amylopectin is considered as one of the largest molecules in nature since it is made up of around 2,000,000 glucose units. It is the major component of starch, making up to 75 to 80% of the molecule (El-Fallal *et al.*, 2012).

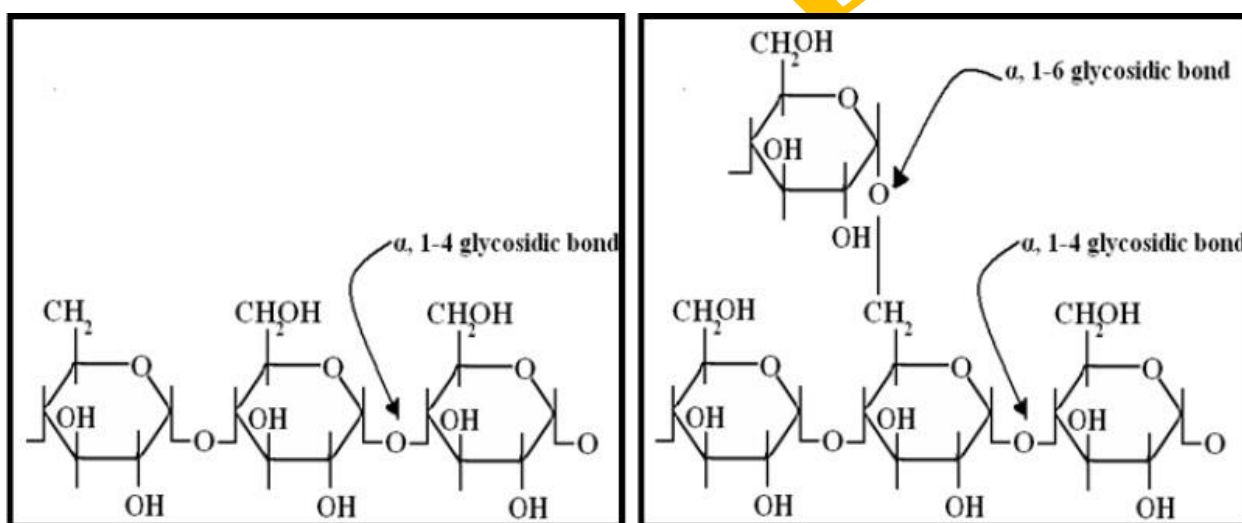

Figure 1.5: Structure of amylose (left) and amylopectin (right) (El-Fallal *et al.*, 2012)

## 1.11. Microbial amylase

Amylase is a very common enzyme found in nature. They are known to be produced most widely by micro organisms such as bacteria and fungi as compared to plants and animals (Dash *et al.*, 2015). The enzymes are produced outside the cell, in order to carry out extracellular digestion (El-Fallal *et al.*, 2012).

Fungi such as *Aspergillus niger*, *Aspergillus oryzae*, *Thermomyces lanuginosus* and *Penicillium expansum* are known to synthesize amylase (El-Fallal *et al.*, 2012). Among bacteria, the *Bacillus* spp is well recognized as amylase producers. Some of these include *Bacillus subtilis*, *Bacillus*

*licheniformis*, *Bacillus amyloliquefaciens*, *Bacillus stearothermophilus*, *Bacillus cereus*, *Bacillus polymyxa*, *Bacillus coagulans* and *Lactobacillus plantarum* (Dash *et al.*, 2015; Parmer and Pandey, 2012; El-Fallal *et al.*, 2012). Other bacteria such as *Clostridium thermosulphurogenes*, *Proteus* and *Pseudomonas* spp are also acknowledged as amylase producers (El-Fallal *et al.*, 2012; Parmer and Pandey, 2012).

*Bacillus* is a common choice of source for industrial amylase production. Different strains of *Bacillus* have different optimal growth conditions and enzymatic production profile. Additionally, the genus produces amylase that is thermostable, has retention to extreme pH, osmolarity and high pressure. Other advantages of this bacterial enzyme production includes use of short fermentation cycles, capacity to produce extracellular enzyme, simple cost effective production, eco friendly behavior, less handling hazard for workers, mass production and easy manipulation of bacterial genes (Gurung *et al.*, 2013). All these characteristics are ideal for industrial amylase production.

Production and characterization of amylase is a hot topic of research. This is due to the vastness of applications of amylase in various sectors, especially in industries. Studies and experiments are being carried out on a large scale in order to detect and determine the easiest ways and optimal conditions to acquire amylase to meet the demands of product manufacture in the industrial world.

### **1.12. Use of microbial amylase in industries**

Amylase is widely used in different industries for the manufacture of various products. Approximately 25% of the enzyme market is comprised of amylase enzyme (Vaseekaran *et al.*, 2010). The first amylase used industrially was fungal amylase in 1894 for the treatment of digestive disorders (Mojsov, 2012). Fungal and bacterial amylases are widely used in the industrial sectors (Vaseekaran *et al.*, 2010). As it is very economical, fungal and bacterial amylase is the best choice of amylase to be used over other sources. Besides, the enzyme production rate is high and the microorganisms can be genetically engineered for the desired quality and quantity of production of amylase (Kaur *et al.*, 2012).

Amylase has a wide range of applications in food industries, textile mills and paper industries. In addition, it is used in the production of alcohol, detergents, bread, glucose and fructose syrup, fruit juices including fuel ethanol. Clinical, medical and analytical chemistry also uses bacterial  $\alpha$ -amylases (Gurung *et al.*, 2013). Apart from industrial purposes, amylase is used in agricultural

sectors to produce digestible feed for animals as well (Roy *et al.*, n.d. para. 7). Uses of amylase for various industrial applications are given in Table 1.2.

**Table 1.2: Uses of amylase in different sectors of industry (Mojsoy, 2012; Sundarram *et al.*, 2014)**

Sector	Uses
Food industry	<ul style="list-style-type: none"> <li>• Production of glucose syrups, crystalline glucose</li> <li>• Production of high fructose corn syrups</li> <li>• Production of maltose syrups</li> <li>• Reduction of viscosity of sugar syrups</li> <li>• Reduction of haze formation in juices</li> <li>• Solubilization and saccharification of starch for alcohol fermentation in brewing industries</li> <li>• Retardation of staling in bread industries</li> </ul>
Detergent industry	Used as an additive to remove starch based dirt
Paper industry	Reduction of viscosity of starch for appropriate coating of paper
Textile industry	Warp sizing of textile fibers
Pharmaceutical industry	Used as a digestive aid
Fuel Alcohol production	Saccharification of starch to yield fermentable sugars needed to produce ethanol

In Bangladesh, various industries use  $\alpha$ - amylase to yield a wide range of products such as high glucose and maltose syrups used in food and pharmaceuticals industries. Amylases are also extensively used to remove starch from cloths in garments and textile industries (Islam *et al.*, 2014). Unfortunately, the country does not have any local production of the enzyme even with the

elevation of its demand due to the expansion of industries. This forces the industries to import amylases from outside the country which is very costly. Moreover, the factories use expensive starch degrading chemicals due to the shortage of amylase (Dash *et al.*, 2015). The chemicals pose a massive threat to the environment due to their non biodegradable and toxic properties. Besides, the used chemicals are improperly dumped into the environment, leading to ominous levels of pollution and damage every day (Ho *et al.*, 2012).

### **Aim of the study**

The use of amylase enzyme is wide spread globally in industrial sectors for the manufacture of a variety of products, including Bangladesh. However, scarcity of commercial amylase production in the country is a major problem for such industries. In order to eliminate the issue, it is necessary to isolate and identify a local amylase producing strain. Also, the amylase enzyme needs to be characterized in order to understand the proper parameters in which it shows best activity.

Therefore this study is conducted with the aim to:

- Isolate a potent amylase producing bacterial strain from soil
- Screen for the best producer of amylase by:
  - Observation of clear zone of starch hydrolysis in starch agar plate
  - Determination of amylase activity of crude amylase produced in submerged fermentation
  - Identify the best isolate by:
    - Biochemical tests analysis, morphological and microscopic characteristics
    - Molecular identification using 16S rRNA gene sequencing and phylogenetic tree construction
- Characterize the crude amylase by determination of:
  - Optimum temperature
  - Optimum pH

## *Chapter 2*

# **Materials and Methods**

### **Materials and methods**

#### **2.1. Duration of study**

The study was conducted from October 2015 to May 2016

#### **2.2. Place of study**

The study was carried out in the Microbiology laboratory of BRAC University, Dhaka, Bangladesh.

#### **2.3. Handling of laboratory apparatus and glassware**

All fresh glassware such as conical flasks, glass pipettes, beakers and glass rods were washed once with tap water and three times with distilled water. They were then air dried prior use. Petri dishes were first sterilized at 160 °C in a sterilizer and then used. All previously used glassware was autoclaved first at 121 °C at 15 psi for 15 minutes in an autoclave machine and then used. Micropipette tips, eppendorfs and falcon tubes were autoclaved first and then used. All kinds of procedures were carried out by the student under the supervision of the lab officers and teaching assistants.

## 2.4. Solutions and reagents

Required solutions and reagents were freshly prepared before use. All chemicals needed were acquired from the laboratory's shelves. None of the solutions or reagents was further purified since they were of a reagent grade. The list of reagents is given in appendix II.

## 2.5. Use of media

Nutrient agar medium was used for short term preservation of bacterial cultures and for subculture purposes. Luria Bertani (LB) broth was used for the growth of bacterial culture before DNA extraction. Starch agar medium was used to screen amylase producing bacteria. A selective media was used during the fermentation of bacteria for amylase production in a shake flask. The compositions of all the media are given in appendix I.

## 2.6. Isolation of bacterial cultures

### 2.6.1. Collection of soil sample

A handful of soil containing decomposed cow manure was collected from a dairy farm in Keraniganj, Bangladesh, in a plastic bag and transported to the laboratory. From the soil sample, 1 g of sample underwent serial dilution and spread plate technique was used transfer the bacteria to nutrient agar media. The plate showing distinct colonies of bacteria was chosen for further work.

### 2.6.2. Screening and selecting potent amylase producing bacteria using starch hydrolysis test

Bacterial colonies were subcultured in freshly prepared dishes containing starch agar by dot method using sterile inoculating needles. The plates were then incubated at 37°C for 48 hours in the incubator. After incubation, the plates were flooded with Gram's iodine. Any formation of clear zone around the colonies were observed and the diameters were measured using a ruler. The isolates which were observed to have the largest clear zones around them where selected. The procedure was carried out three times for proper confirmation. The clear zone ratio was calculated using the following formula,

Diameter of clear zone (mm)

Clear zone ratio = -----

## **2.7. Collection of crude amylase enzyme from bacteria**

Selective fermentation media was used in order to allow proper growth of amylase producing bacteria and fermentation was carried out at favorable conditions to trigger the bacteria to release the amylase enzyme in the extracellular media. Afterwards, the media was collected and underwent centrifugation to separate the supernatant and solid components of the media. The supernatant contained the crude amylase enzyme and was used in enzyme assay.

### **2.7.1. Inoculum preparation**

The bacterial isolates were streaked on separate fresh nutrient agar media. The plates were incubated at 37°C for 24 hours. A loop full of the freshly grown colony was inoculated in separate screw cap test tubes containing a liquid media (Yaser *et al.*, 2013) selective for amylase producing bacteria. The media was prepared using the following composition: 5 g/L soluble starch, 5 g/L yeast extract, 2.5 g/L (NH<sub>4</sub>)<sub>2</sub>SO<sub>4</sub>, 0.2 g/L MgSO<sub>4</sub>·7H<sub>2</sub>O, 3 g/L KH<sub>2</sub>PO<sub>4</sub> and 0.25 g/L CaCl<sub>2</sub>·2H<sub>2</sub>O (Yaser *et al.*, 2013). The test tubes were incubated at 37°C for 24 hours to allow bacterial growth.

### **2.7.2. Fermentation**

2.5 ml of the liquid media was transferred to a 250 ml Erlenmeyer flask containing 50 ml of fermentation media with the same composition as the liquid media using a micropipette. Each bacterial isolate was transferred to separate flasks. The flasks were incubated in a shaking incubator for 48 hours at 37°C and 150 rpm. The procedure was carried out in triplicates.

### **2.7.3. Separation of crude enzyme from culture media**

After incubation, enough culture fluid was collected. The culture fluid was then centrifuged at 6000 rpm for 10 minutes. The supernatant obtained was the crude enzyme. It was stored at 4°C until use.

## 2.8. Enzyme assay to determine amylase activity

### 2.8.1. Enzyme assay

The DNS method was used to determine the amylase activity of each bacterial isolate. The isolate which showed the highest activity was chosen (Ghose, 1987).

Substrate solution was made by dissolving 1% starch solution in citrate buffer (ph 4.8). The supernatant (crude enzyme) was diluted to 10 folds by mixing 1 ml of the supernatant to 9 ml distilled water. To each screw cap test tube, 1 ml substrate solution was added, followed by 1 ml citrate buffer (pH 4.8) and 1 ml supernatant (crude enzyme). The test tubes were incubated at 50°C for 30 minutes in a water bath. After incubation, 1.5 ml DNS solution was added to each test tube to stop the reaction. The test tubes were left undisturbed at room temperature for 10 minutes. The test tubes were then boiled at 100°C for 10 minutes in the water bath. After boiling, the test tubes were cooled down to room temperature under running tap water. The colour intensity of the solution was observed by measuring the optical density (OD) using a spectrophotometer at 540 nm. The reading was compared to a prepared blank solution. The process was carried out in triplicates. The concentration of glucose produced for each solution was obtained from the glucose standard curve. The activity of amylase was calculated using the following formula. One unit of amylase activity is defined as the amount of amylase required to catalyze the formation of reducing sugar which is equal to 1 mole of D glucose per minute under assay conditions (Kaur *et al.*, 2012).

$$\text{Enzyme activity (U/ml)} = \frac{\text{Reducing sugar (product concentration)} \times 1000 \times \text{Dilution factor}}{\text{Molecular weight of glucose} \times \text{Incubation time (minute)}}$$

The crude enzyme of the bacterial isolate having the highest activity was chosen for further work.

### 2.8.2. Formation of glucose standard curve

In this experiment, a glucose standard curve was formulated by the following method in order to determine the amount of reducing sugar produced by the amylase enzyme of bacterial isolate.

To separate test tubes, different concentrations of glucose solutions were added. The concentrations were made according to the following composition illustrated in Table 2.1.

**Table 2.1: Amount of components used to formulate the glucose standard curve**

Concentration of glucose(mg/ml)	Mass of glucose (mg)	Volume of distilled water (ml)
Blank	0	1
0.2	0.2	1
0.4	0.4	1
0.6	0.6	1
0.8	0.8	1
1.0	1.0	1
1.2	1.2	1

To each concentration, 3 ml of DNS solution was added. The test tubes were boiled at 100°C for 10 minutes in a water bath. The intensity of colour of each solution was measured in optical density (OD) in a spectrophotometer at 540 nm. A graph was plotted with the acquired data where x-axis was labeled with glucose concentration (mg/ml) and y-axis was labeled absorbance (540 nm).

## **2.9. Determination of specific amylase activity**

### **2.9.1. Extracellular protein concentration**

In order to determine the specific enzyme activity of the selected isolates, the Folin-Lowry method for total protein estimation was used (Lowry *et al.*, 1951).

To each test tube, 0.2 ml crude enzyme (supernatant) was added. To that, 2 ml alkaline copper sulphate (reagent C) was added which was made using reagent A and reagent B prior use. The test

tubes were incubated in the dark for 10 minutes. After incubation, 200  $\mu$ l of Lowry reagent was added to the test tubes. A further incubation was done for 30 minutes in the dark. The absorbance of the solutions was then measured in optical density (OD) using a spectrophotometer at 650 nm. The readings were compared to a prepared blank solution. The OD readings were used to find out the unknown protein concentration from the protein standard curve. The specific enzyme activity was measured using the following formula,

$$\text{Specific activity (U/mg)} = \frac{\text{Enzyme activity (U/ml)}}{\text{Extracellular protein concentration (mg/ml)}}$$

### 2.9.2. Formation of protein standard curve

For the determination of unknown protein concentration in the supernatant, a protein estimation curve was plotted.

In different test tubes, different dilutions of BSA solutions were prepared by mixing stock BSA solution (1 mg/ ml) and water according to the compositions given on Table 2.2.

**Table 2.2: Amount of components used to formulate the protein standard curve**

BSA (ml)	Water (ml)	Sample concentration(mg/ml)	Sample volume (ml)	Alk.CuSO4 (ml)	Lowry reagent (ml)
0.25	4.75	0.05	0.2	2	0.2
0.50	4.50	0.1	0.2	2	0.2
1	4	0.2	0.2	2	0.2
2	3	0.4	0.2	2	0.2
3	2	0.6	0.2	2	0.2
4	1	0.8	0.2	2	0.2
5	0	1.0	0.2	2	0.2

The final volume in each of the test tubes was 5 ml. From these different dilutions, 0.2 ml protein solution was pipette to different test tubes and 2 ml of alkaline copper sulphate reagent (analytical reagent) was added. The solutions were mixed properly and incubated at room temperature for 10 minutes. After incubation, 0.2 ml of reagent Folin Ciocalteau solution (reagent solutions) was added to each tube and incubated for 30 minutes. The absorbance of each solution was measured at 650 nm using a spectrophotometer. The readings were compared to a prepared blank.

## **2.10. Phenotypic identification of bacterial strain**

The selected bacterial isolate was identified via the following methods.

### **2.10.1. Microscopic observation**

The bacterial isolate underwent microscopic observation after different staining methods.

#### **2.10.1.1. Gram staining**

A bacterial smear was prepared in on a clean glass slide. It was allowed to air dry and heat fixed by passing the slide through the flame of a Bunsen burner very swiftly. At first it was stained with crystal violet for 1 minute and washed. Gram's iodine was added and washed off. After that it was decolorized with 95% ethyl alcohol. The smear was stained again with safranin for 45 seconds and washed. The smear was then observed under the microscope with 1000X magnification.

#### **2.10.1.2. Spore staining**

A bacterial smear was made in sterile conditions. The smear was air dried and heat fixed. The slide was flooded with malachite green and placed on top of a beaker containing boiling water and left for 3 minutes. After washing, it was stained with safranin for 30 seconds and washed.

The smear was air dried and observed under the microscope.

### **2.10.2. Cultural characterization**

The colony morphology of the bacteria was determined by observing the size, form, colour, pigmentation, elevation, margin, texture and opacity of the colony. In this experiment, the bacterial cultures where freshly grown in nutrient agar media by three way streaking method and their colony morphology was observed. Photographic images were taken for visual preservation.

### **2.10.3. Biochemical characterization**

In this experiment, different biochemical tests were carried out for the bacterial isolate. The following biochemical tests were performed using 24 hours fresh bacterial cultures grown on nutrient agar media. The media were autoclaved at 121°C for 15 minutes at 15 psi, wherever required.

#### **i. Catalase test**

A clean glass slide was marked with the name of the bacterial isolate. To the opposite side, a drop of hydrogen peroxide was added. To the drop, a loopful of bacterial isolate was mixed. Any immediate formation of bubbles was observed. **ii. Oxidase test**

A clean filter paper was placed on a Petri dish. A drop of oxidase reagent was added on the filter paper. Using an inoculating loop, a small amount of bacterial culture was streaked on the drop of oxidase reagent. Any formation of dark purple colour of the reagent was observed.

#### **iii. MRVP test**

The MRVP broth was formulated, boiled and 7 ml broth was added to each test tube. The test tubes were then autoclaved to sterilize the broth. After that, to each test tube, a loop of 24 hours fresh culture was inoculated. The test tubes were incubated at 37°C for 24 hours. After incubation, 3.5 ml of the broth was transferred from each test tube to clean test tubes. The remaining broth was reincubated for another 24 hours.

#### **a) VP test**

To the 3.5 ml broth, 0.6 ml (12 drops) of Barritt's reagent A was added followed by 0.2 ml (6 drops) of Barritt's reagent B. The tubes were gently shaken to expose the medium to atmospheric oxygen for 1 minute. The tubes were left undisturbed for 10 to 15 minutes.

Formation of any red-pink colour of the broth was observed.

#### **b) MR test**

After 48 hours of incubation of the remaining broth, 2.5 ml the MRVP broth was transferred to clean test tubes. Five drops of methyl red was added to the broth. Immediate formation of red colour was observed.

#### **iv. TSI test**

The TSI media was boiled and 7 ml of the media was added to each test tube. The media was autoclaved. After sterilization, the media was left to cool by keeping the test tubes in a slanted position in order to form a butt and a slant. An inoculating needle was used to pick up a colony from a fresh 24 hour culture plate. The needle was used to inoculate the media. The test tubes were incubated by loosening fitting the caps in order to allow air flow. Incubation was done at 37°C for 24 hours. The appearance of the media was observed after incubation.

#### **v. Simmon's citrate test**

The media was prepared and 2 ml media was added to clean vials. The vials were autoclaved and then left to cool at a slanted position in order to create a butt and slant. An inoculating needle was used to pick up a single colony from a 24 hours fresh bacterial culture. The slant of the media was streaked from bottom to top using a zigzag motion with the needle. The vials were incubated at 37°C for 48 hours. The colour of the media was observed after incubation.

#### **vi. MIU test**

The media was formulated, boiled and autoclaved. Some empty test tubes were autoclaved as well. After autoclave, the media was left to cool so that the temperature went down to 50°C. On a separate flask, 40% urea solution was made and filtered using a HEPA filter. To the cooled media, the urea solution was added and mixed. A sterile glass pipette was used to transfer 6ml of the media to the autoclaved test tubes. The media was left to cool down completely until it had a semi solid consistency. Using an inoculating needle, a colony from a 24 hours fresh bacterial culture was picked up and inoculated in the medium by stabbing the needle down into the media. The needle was then withdrawn and taken out in a vertical manner. The test tubes were incubated at 37°C for 24 hours. The appearance and colour of the media was observed after incubation.

### **vii. Gelatin hydrolysis**

The gelatin medium was prepared, boiled and 3 ml media was placed in clean vials using a glass pipette. The vials were autoclaved and then left to cool for the gelatin to solidify. An inoculating needle was used to pick up a colony from a 24 hours fresh culture plate and used to inoculate the gelatin media by stabbing into the media and withdrawing the needle straight up. A control was used in this method in which no bacterial isolate was inoculated. All the vials were incubated at 37°C for up to 1 week and checked every day for gelatin liquefaction. The liquefaction was checked by placing the vials in an ice bath and kept there for 30 minutes. After that, it was observed that whether the gelatin was in liquid form or had solidified.

### **viii. Nitrate reduction test**

The nitrate broth was made, boiled and 5 ml broth was added to each test tube using a glass pipette. The broth was autoclaved and left to cool. Using an inoculating loop, a single colony was picked from a 24 hours fresh bacterial culture and used to inoculate the broth in each test tube. The test tubes were incubated at 37°C for 24 hours. After incubation, 5 drops of each reagent A and reagent B was added to the test tubes respectively. Formation of a red colour was observed.

### **ix. MSA plate test**

The MSA media was formulated, boiled and autoclaved. After that, the media was poured on a Petri dish plate and allowed to solidify. An inoculating loop was used to pick a single colony of a 24 hours fresh bacterial culture and used to streak the bacteria on the media using the 4 way streaking method. The loop was burned between each streak in order to get isolated colonies. The plate was incubated at 37°C for 48 hours. The plate was observed after incubation. x.

### **Casein hydrolysis test**

In a conical flask, 50 ml agar solution was made, boiled and autoclaved. In a separate flask, 50 ml distilled water was autoclaved. After that, 1.4 ml skim milk powder was added to the distilled water and stirred using a sterile glass rod for the milk powder to dissolve. The mixture was heated in the microwave oven for 1 minute. The heated mixture was then added to the agar solution and stirred. The solution was then poured onto designated Petri dish plates and left to solidify. An inoculating needle was used to pick a single colony from a 24 hours fresh bacterial culture and was

used to touch the media in dot like manner. The plates were incubated at 37°C for 24 hours. Any clear zone was detected on the plates after incubation.

#### **xi. Hemolysis of blood**

A selective media called blood agar media was used in this test. At first, the required amount of blood agar base powder was weighed and dissolved in distilled water. The solution was heated for proper mixing and autoclaved. After that, the temperature of the blood agar base was allowed to come down to 50°C and then 5% v/v sterile defibrinated blood was added. The solution was swirled for proper mixing and poured into designated Petri dish plates and left to solidify. A loop of 24 hours old bacterial culture was then streaked onto the plates and incubated for 24 hours. The type of hemolysis was observed after incubation. **xii.**

#### **Cellulose degradation**

Carboxymethylcellulose (CMC) media was made, boiled and autoclaved. The media was poured on designated Petri dish plates. After solidification of the media, an inoculating needle was used to pick a colony of a 24 hours fresh bacterial colony and used to touch the CMC media in a dot like manner. The plates were incubated at 37°C for 48 hours. After incubation, Gram's iodine was used to flood the plates. Any zone of clearance was observed around the bacterial colony in the plate.

#### **xiii. Growth on anaerobic condition**

Nutrient agar was made, boiled and autoclaved. The nutrient agar was poured in designated Petri dish plates. In the nutrient agar media plates, the bacterial strain was streaked using an inoculation loop using 3 way streaking method. The plates were placed in a tin jar. A candle was lit and also placed in the jar beside the plates in order to burn off all the oxygen present inside the jar. The jar was tightly shut to prevent any air to get inside. The jar was then placed in an incubator at 37°C for 24 hours. After incubation, any growth in the nutrient agar plates was observed.

#### **xiv. Growth at 45°C and 65°C**

Nutrient agar was made, boiled and autoclaved. The nutrient agar was poured in designated Petri dish plates. Using an inoculating loop, a colony of the bacterial strain was picked up and streaked on nutrient agar plates in a three way streaking method. Some plates were incubated at 45°C and some were incubated at 65°C for 24 hours. Any growth on the plates was observed after incubation.

#### **xv. Growth in 7% NaCl**

Nutrient agar was made, and 7% NaCl salt was added to it. The nutrient agar was boiled, autoclaved and then poured into the designated Petri dish plates. An inoculating loop was used to streak the bacterial strain in the nutrient agar plates in a three way streaking method. The plates were incubated at 37°C for 24 hours. After incubation, any growth on the plates was observed.

#### **xvi. Fermentation of sugar: Xylose, Maltose, Sucrose, Glycerol and Fructose**

Different sugar broths were made, and 5 ml of the broths were placed separately in clean test tubes. The test tubes were autoclaved. Using a spatula, a small amount of phenol red powder was added to each test tube which turned the solutions red. An inoculating needle was used to pick up a single colony of the bacterial strain and used to inoculate a test tube in the same manner. The step was repeated for all test tubes. The test tubes were incubated at 37°C for 24 hours. Any formation of yellow colour of the broths was observed.

### **2.11. Genotypic identification of bacterial strain**

The bacterial strain was further identified by sequencing the 16S rRNA gene of bacteria. This was done by the following methods.

#### **2.11.1. DNA extraction**

The total genomic DNA was extracted using the Wizard® Genomic DNA Purification Kit (Promega, USA).

The bacterial isolate was first grown on Luria Bertani media for 24 hours at 37°C in an incubator. After incubation, 2 ml of the liquid culture was added to a 3 ml microcentrifuge tube.

Centrifugation of the tubes was carried out at 13500 rpm for 3 minutes to pellet the cells. The supernatant was discarded and the pellet was resuspended in 480 µl of 50 mM EDTA. The

resuspended cells were used to extract cellular DNA according to the protocol provided by Wizard® Genomic DNA Purification Kit (Promega, USA). The extracted DNA was stored at 4°C for further work.

### 2.11.2. Amplification of extracted DNA using Polymerase Chain Reaction

From the extracted DNA, the 16S rRNA gene was amplified using Polymerase Chain Reaction. This was done using the following primers mentioned in Table 2.3.

**Table 2.3: Primers used in the PCR reaction**

Primer	Sequence	Type
Forward: 27F	5'-AGA GTT TGA TCM TGG CTC AG- 3'	Universal
Reverse: 1492R	5'-GGT TAC CTT GTT ACG ACT T- 3'	Universal

The master mix was made manually by adding *Taq* Reaction Buffer, dNTP and Nuclease free water in a PCR tube. The Forward and Reverse Primers, template DNA and *Taq* DNA Polymerase enzyme were added right before loading the sample in the PCR machine. The composition of the reaction set up (Biolabs Inc, n.d.) is given in the Table 2.4. All the steps were performed on ice.

**Table 2.4: Reaction set up for PCR carried out for 50 µl reaction volume**

Component	Amount	Final Concentration
10X <i>Taq</i> Reaction Buffer	5 µl	1X
10 mM dNTP	1 µl	200 mM
10 µM Forward Primer	1 µl	0.2 µM
10 µM Reverse Primer	1 µl	0.2 µM
Template DNA	2 µl	< 1000 ng
<i>Taq</i> DNA Polymerase	0.25 µl	1.25 units
Nuclease Free Water	39.75 µl	

The thermal cycle (Elijah *et al.*, 2014) that was followed for the sample is given in Table 2.5. **Table**

**2.5: PCR reaction condition**

PCR condition	Temperature	Time
---------------	-------------	------

Initial denaturation	94°C	2 minutes
Denaturation	94°C	30 seconds
Annealing	50°C	30 seconds
Extension	72°C	2 minutes
Final extension	72°C	5 minutes

The PCR was carried out for 30 cycles. Afterwards, the amplicon was stored at -20°C for further work.

### **2.11.3. Detection of DNA using agarose gel electrophoresis**

After PCR reaction, amplification was checked by horizontal electrophoresis in 1.0% agarose slab gel in Tris–borate EDTA (TBE) buffer. Agarose was dissolved in 1X Tris borate EDTA buffer to give a final concentration of 1.0% agarose and was heated to dissolve in a microwave oven for about 30 seconds. After that it was allowed to cool down to about 50°C. To the cooled agarose, 2 µl Ethidium Bromide (EtBr) stain was added and mixed in order to stain the DNA bands. The agarose was then poured on the tray previously set with the comb and allowed to solidify. 6 µl aliquot of the PCR product was mixed 2 µl of loading dye and was loaded into the individual wells of the gel. A ladder of size 1kb plus (Invitrogen, USA) was used to ensure amplification of the desired gene and measure the exact product size which was estimated to be within 1,500 bp. The DNA bands were observed on a UV transilluminator at 365 nm.

### **2.11.4. Purification of DNA**

After observing the presence of the desired DNA in the PCR amplicon, DNA was purified from the amplicon using the Wizard® SV Gel and PCR Clean-Up System (Promega, USA).

### **2.11.5. Measurement of DNA concentration and purity**

DNA concentration was measured using NanoDrop 2000 spectrophotometer. To the NanoDrop, 1.5 µl of nuclease free water was used as blank. The blank was removed and 1.5 µl of sample was loaded. DNA concentration was measured in ng/µl unit. The OD260 /OD280 ratio was measured with the software which indicated the purity of the sample.

### **2.11.6. DNA sequencing**

The DNA sample was sent to the '1<sup>st</sup> BASE Laboratories' in Malaysia via Invent Technologies Ltd. where it was sequenced using the Sanger method.

### **2.11.7. Bioinformatics analysis**

The acquired gene sequence trace was trimmed and cleaned using Mega6 and Lasergene Seqman software. The cleaned genetic sequence was then compared to different 16S rRNA gene of different bacteria in the reference RNA sequences (16S ribosomal RNA) database of NCBI Nucleotide BLAST website using Blastn tool in order to identify the genus of the selected isolate.

The query sequence was converted to FASTA format using EMBOSS SEQRET website and was then used to create a phylogenetic tree using Mega6 software.

## **2.12. Characterization of amylase enzyme**

The amylase enzyme was characterized by determining the optimum temperature and pH of the enzyme activity (Irfan *et al.*, 2012). Fermentation was carried out in the same procedure as before to acquire the crude enzyme (supernatant).

### **2.12.1. Determination of optimum temperature**

To different screw cap test tubes, 1 ml of 1% substrate solution (1% starch agar in phosphate buffer, pH 6.5) was added along with 1ml phosphate buffer (pH 6.5) and 1 ml diluted (5 fold) crude enzyme. The test tubes were incubated at different temperatures starting from 25°C to 85°C for 30 minutes in a water bath. The reactions were then stopped using 1.5 ml DNS solution. The test tubes were left undisturbed for 10 minute at room temperature. After that, the test tubes underwent boiling at 100°C for 10 minutes in a water bath. The test tubes were then cooled to room temperature under running tap water. The intensity of colour for each test tube was measured at 540 nm using a spectrophotometer. The readings were compared to a blank solution for each temperature. The temperature at which the highest activity was observed was noted.

### **2.12.2. Determination of optimum pH**

Different substrate solutions were made by dissolving 1% soluble starch in different pH solutions starting from 3 to 10. To separate screw cap test tubes, 1 ml of different 1% substrate solution was

added along with 1 ml of the respective buffers; 0.05 M citrate buffer (pH 3 to 5), 0.05 M sodium phosphate buffer (pH 6 and 7), 0.05 M Tris- HCl (pH 8 and 9) and 0.05 M glycine NaOH (pH 10). 1ml diluted (5 fold) crude enzyme was added to these buffers as well. The test tubes were incubated at 75°C (optimum temperature) for 30 minutes in a water bath. The reactions were then stopped using 1.5 ml DNS solution. The test tubes were left undisturbed for 10 minute at room temperature. After that, the test tubes underwent boiling at 100°C for 10 minutes in a water bath. The test tubes were then cooled to room temperature under running tap water. The intensity of colour for each test tube was measured at 540 nm using a spectrophotometer. The readings were compared to a blank solution for each temperature. The pH at which the highest activity was observed was noted.

### **2.13. Culture preservation**

20% glycerol broth was used for preservation purpose. One loop-full of bacterial inoculum was transferred to 5 ml nutrient broth medium and incubated at 37°C for 24 hours. Then, 800 µl of bacterial suspension was mixed with 200 µl autoclaved glycerol in 1.5ml autoclaved centrifuge tubes. It was then sealed with parafilm tapes and stored in -20°C refrigerator.

## *Chapter 3*

# **Results**

## Results

### 3.1. Isolation and selection of amylase producing bacteria from soil

The source of bacteria used was soil mixed with decayed cow manure from a farmyard in Keranigang. After serial dilution and spread plating in nutrient agar plates, the bacteria acquired from  $10^{-5}$  dilution were selected. From the sample, 48 isolates were selected and streaked on starch agar plates. From there, using the Gram's iodine method, 17 isolates were observed to give zone of clearance around their colonies. Since 36% of the bacteria were found to be amylase producing, this type of soil sample is considered to be a moderate source of amylase producing bacteria. 58% of the isolates did not produce amylase and 6% isolates did not grow at all in starch agar media (Figure 3.1). After carrying out the procedure three times for confirmation, two isolates, 14 and 28, which produced the largest ratio of clear zone were selected. Isolate 14 had a clear zone ratio of 2.14 and isolate 28 had a clear zone ratio of 2.41. Table 3.1 demonstrates the results obtained from starch agar medium and the comparison of average clear zone ratio of amylase producing bacteria on starch agar plates is illustrated in Figure 3.2.

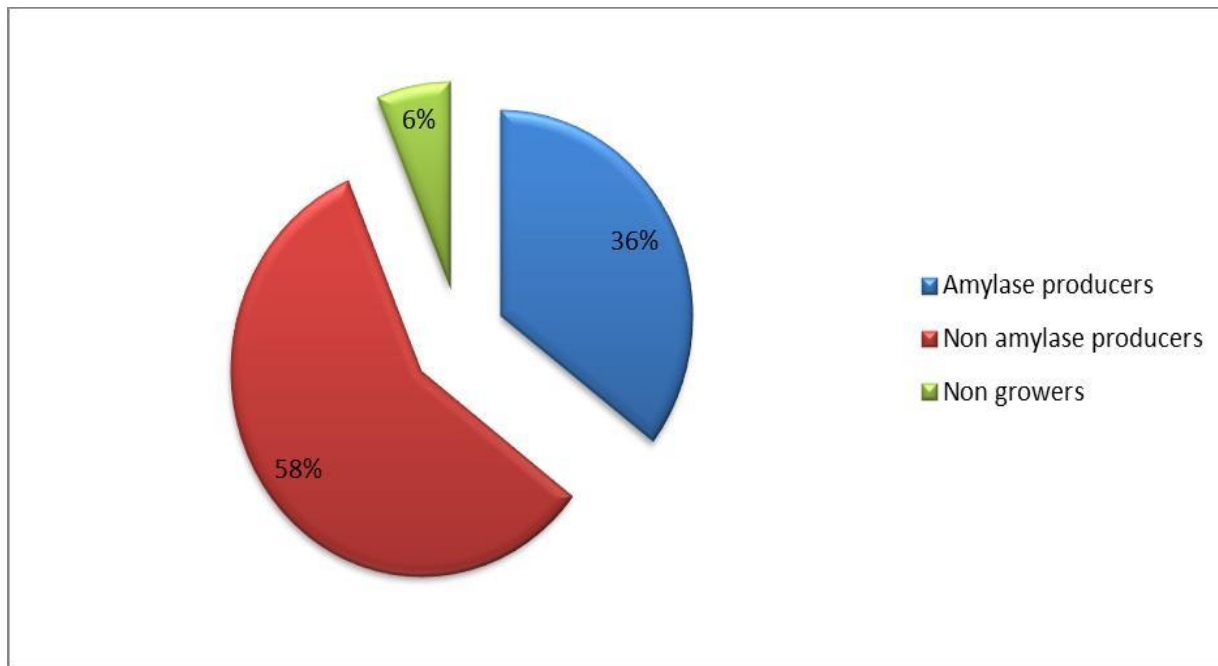
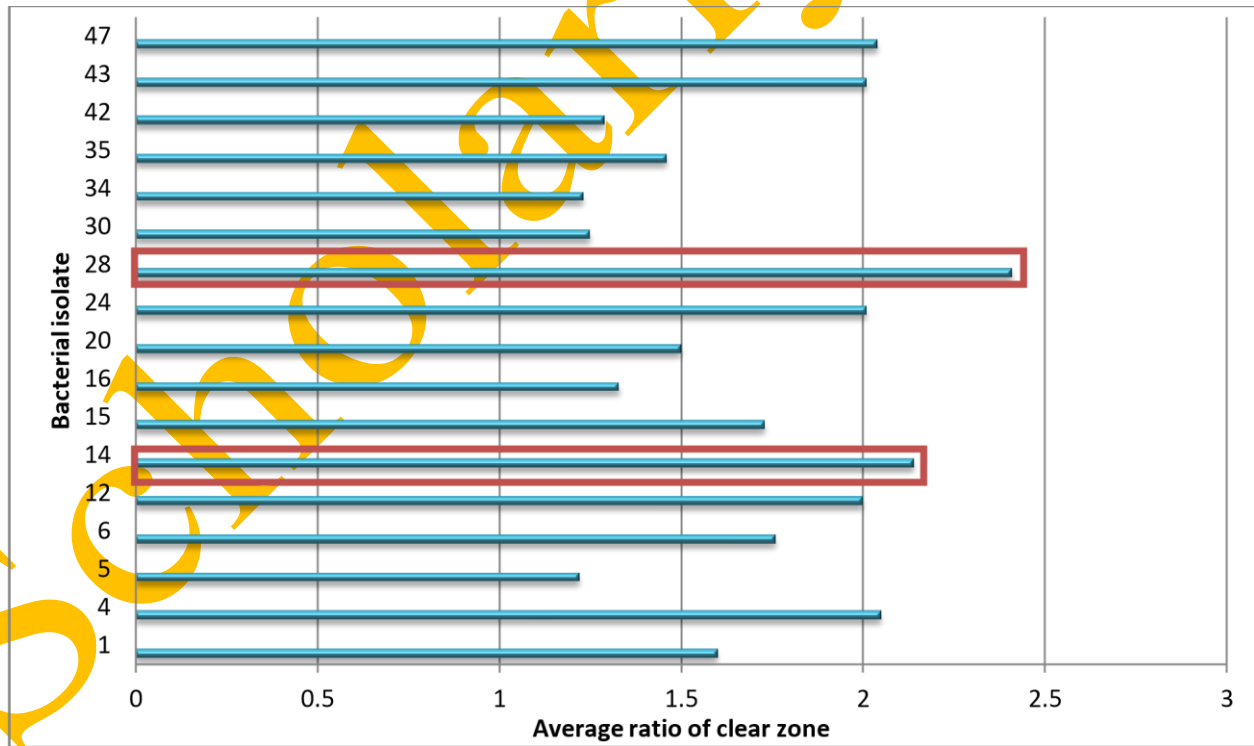

**Figure 3.1: Percentage of different types of bacteria obtained from starch agar plates**

**Table 3.1: Average ratio of clear zones of selected colonies from nutrient agar media on starch agar media**

Isolate number	Average clear zone ratio	Isolate number	Average clear zone ratio
1	1.60	25	NH
2	NH	26	NH
3	NH	27	NH
4	2.05	28	2.41
5	1.22	29	NH
6	1.76	30	1.25
7	NH	31	NH
8	NH	32	NH
9	NH	33	NH
10	NH	34	1.23
11	NH	35	1.46
12	2.0	36	NH

13	NH	37	NH
14	2.14	38	NG
15	1.73	39	NH
16	1.33	40	NH
17	NG	41	NH
18	NH	42	1.29
19	NH	43	2.01
20	1.50	44	NH
21	NH	45	NH
22	NG	46	NH
23	NH	47	2.04
24	2.01	48	NH



**Figure 3.2: Comparison among the average ratio of clear zones of the amylase producing bacteria on starch agar plates**



**Figure 3.3: Zone of clearance produced by isolate 14 (left) and isolate 28 (right) on starch agar media**

### 3.2. Enzyme assay to select the highest amylase producing bacteria

By using the DNS method and glucose standard curve (Figure 3.4), it was observed that isolate 14 showed an activity of 0.123 U/ml while isolate 28 showed an activity of 0.076 U/ml (Figure 3.5). Since to a greater level of amylase activity was obtained for colony 14, it was chosen for further identification.

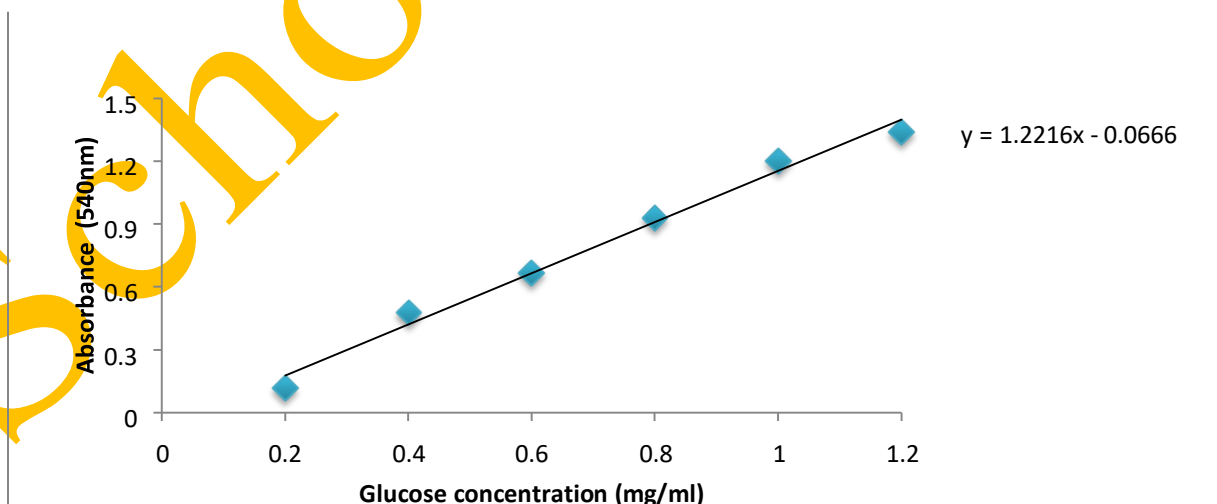

**Figure 3.4: Glucose standard curve**

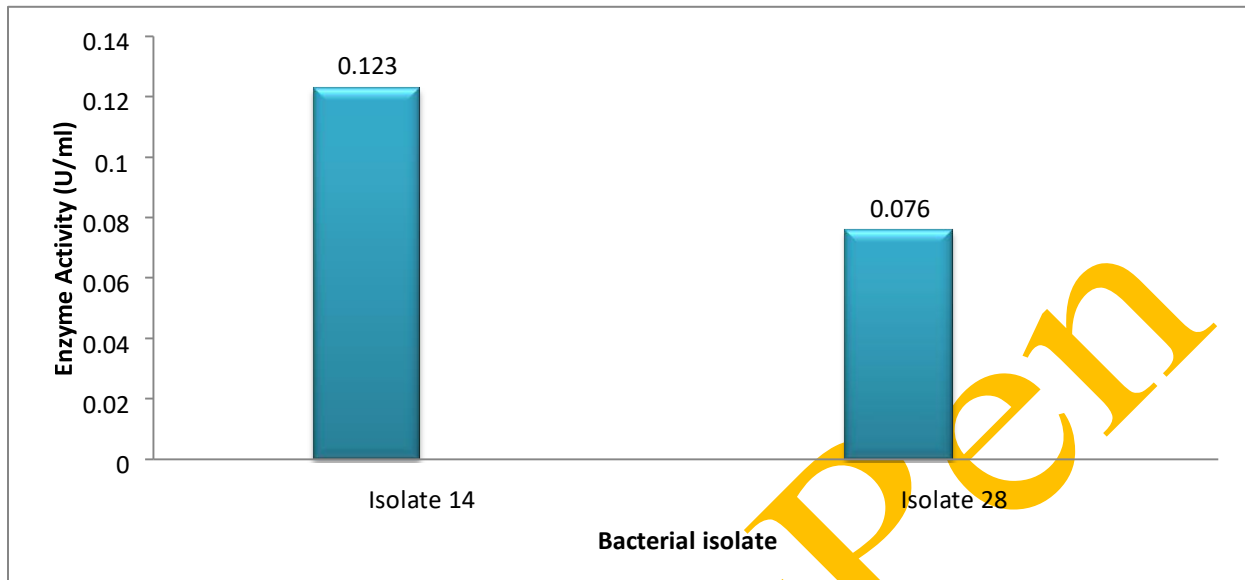

**Figure 3.5: Enzyme activities of isolates 14 and 28**

### 3.3. Determination of specific activity of amylase enzyme

The specific activity of isolates 14 and 28 were determined using the Folin – Lowry method and the protein standard curve (Figure 3.6). Isolates 14 and 28 showed an activity of 0.173 U/mg and 0.128 U/mg respectively as shown in Figure 3.7. Since isolate 14 has a higher specific activity between the two, it can be concluded that isolate 14 is a better amylase producer than isolate 28.

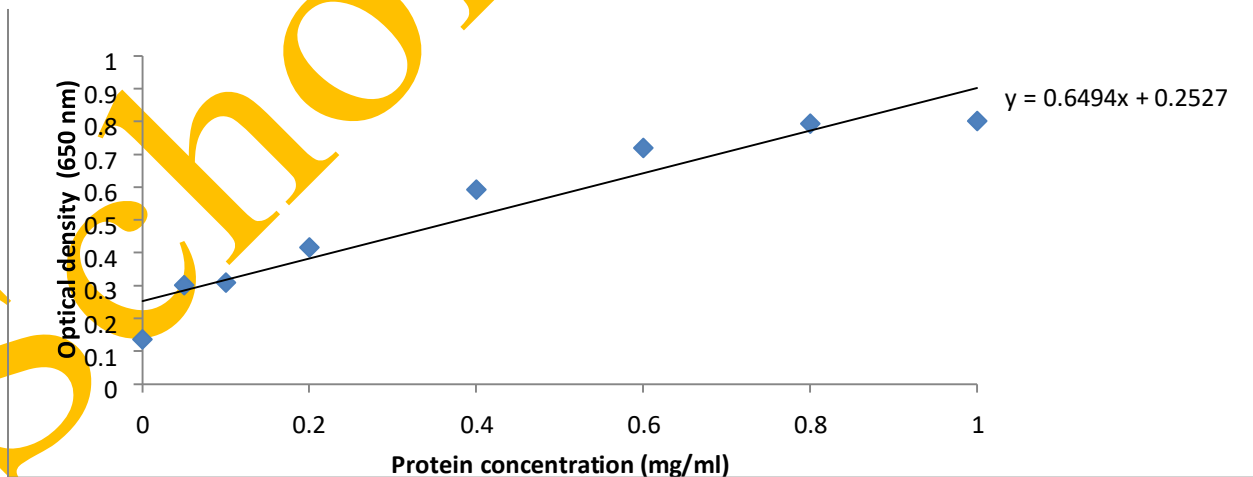

**Figure 3.6: Standard protein estimation curve**

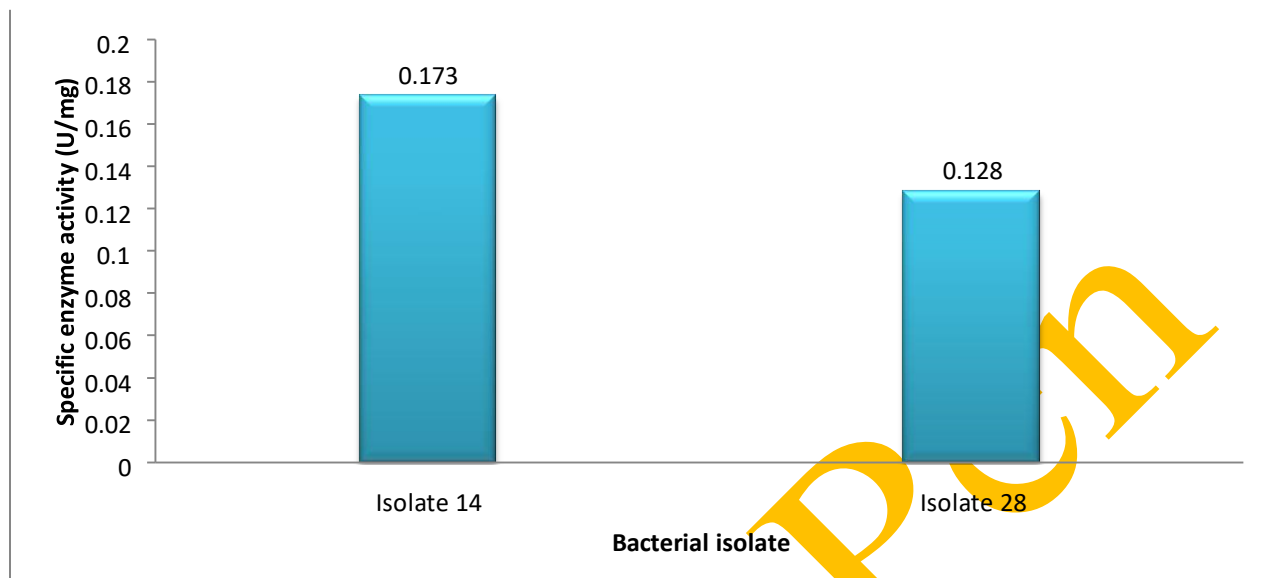

**Figure 3.7: Specific enzyme activities of isolates 14 and 28**

### **3.4. Identification of selected amylase producing bacteria**

#### **3.4.1. Gram staining**

The selected bacteria were observed to be Gram positive rods arranged in chains when visualized under the microscope after Gram staining. This is shown in figure 3.8.

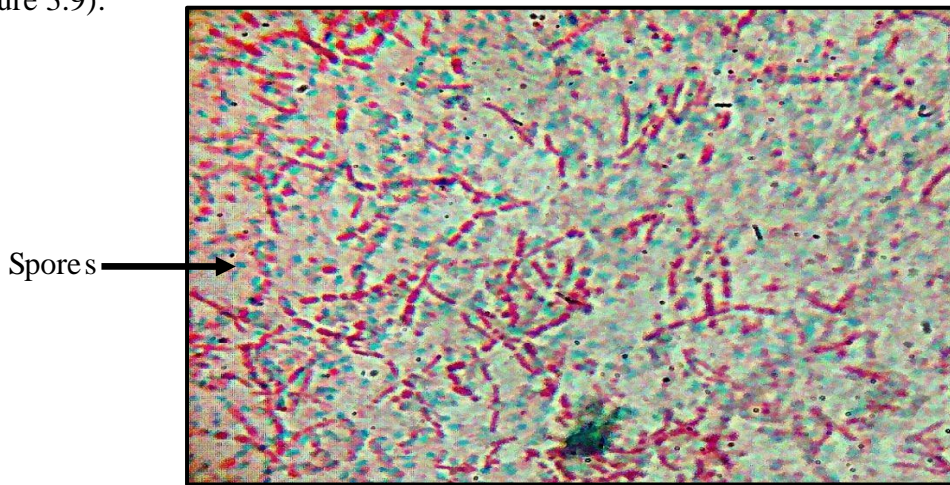

**Figure 3.8: Appearance of Gram positive isolate 14 under the microscope**

#### **3.4.2. Spore staining**

Using spore staining technique it was observed that isolate 14 is an endospore forming bacteria

(figure 3.9).



**Figure 3.9: Appearance of isolate 14 after spore staining under the microscope. The spores are stained green whereas the bacterial cells are stained red**

### 3.5. Colony morphology

The colony characteristics of bacteria were observed from a freshly streaked culture in a nutrient agar plate. Table 3.2 illustrates the colony morphology of isolate 14.

**Table 3.2: Colony morphology of isolate 14**

Characteristics	Appearance
Pigmentation	Opaque with no pigment
Colour	Off white
Form	Circular
Margin	Entire
Elevation	Umbonate
Texture	Matt
Size	Large



**Figure 3.10: Appearance of isolate 14 on nutrient agar medium**

### **3.6. Biochemical tests**

The following biochemical results were performed for isolate 14:

- Catalase test
- Oxidase test
- MRVP test
- TSI test
- Citrate utilization test
- MIU test
- Cellulose degradation test
- Gelatin hydrolysis test
- Nitrate reduction test
- MSA plate test
- Casein hydrolysis test
- Blood hemolysis test
- Growth in anaerobic condition
- Growth at 45°C and 65°C
- Growth in 7% NaCl

- Fermentation of sugar: xylose, maltose, sucrose, glycerol and fructose

It was observed that, a positive result was obtained for catalase test, indole production, cellulose degradation, gelatin and casein hydrolysis and reduction of nitrate. On the other hand, the result was negative for oxidase test, both MR and VP test, utilization of citrate, motility, urease production and MSA plate test. Also, anaerobic condition and 45°C favoured the growth of the bacteria whereas the opposite was observed for 65°C and 7% NaCl. In terms of sugar fermentation, all the sugars mentioned above were fermented except xylose. The results are presented in Table 3.3 where a positive result is represented by + and a negative result is represented by -.

**Table 3.3: Biochemical tests performed and results obtained for isolate 14**

Biochemical tests	Results
Catalase	+
Oxidase	-
Voges Proskauer (VP)	-
Methyl red	-
Nitrate reduction	+
Citrate	-
Gelatin hydrolysis	+
Cellulose degradation	+
MSA plate test	-
Indole production	+
Casein hydrolysis	+
Anaerobic growth	+
Growth at 45°C	+
Growth at 65°C	-
Growth in 7% NaCl	-
Hemolysis of blood	+, β hemolysis
Fermentation of xylose	-

Fermentation of maltose	+
Fermentation of sucrose	+
Fermentation of glycerol	+
Fermentation of fructose	+
MIU	Motility: -, Urease production: -, Indole production: +
Triple Sugar Iron (TSI)	Red slant, yellow butt: Glucose fermentation : +, Lactose fermentation: - Gas and hydrogen sulphide production: -

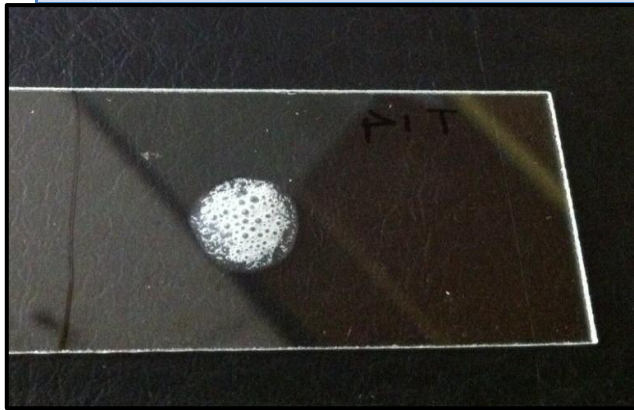

(a) Catalase test

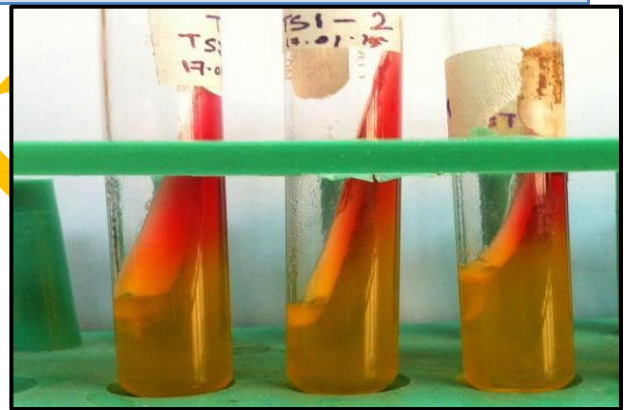

(b) Triple sugar iron test



(c) Citrate utilization test



(d) Growth in anaerobic condition

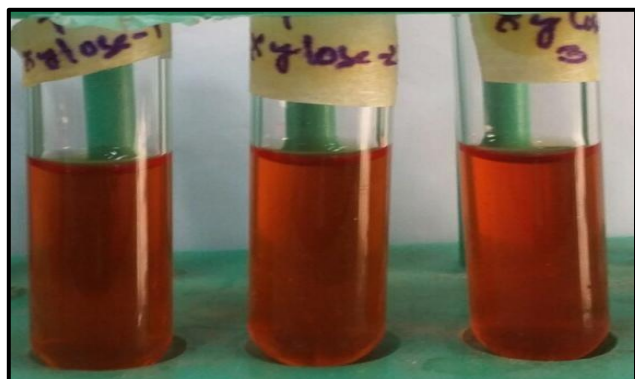

(e) Fermentation of xylose



(f) Fermentation of maltose

**Figure 3.11: Results of some of the biochemical tests performed**

According to the presumptive identification results, it was assumed that isolate 14 might belong to the genus '*Bacillus*'. For confirmation, genotypic identification processes were carried out.

### 3.7. Amplification and detection of 16S rRNA of the bacterial strain

After the extraction of the total genome and amplification of the 16S rRNA gene of the bacterial isolate 14, it was observed through agarose gel electrophoresis that the size of the 16S rRNA gene for this particular bacterial isolate is just below 1,650 base pairs. In Figure 3.12, lane 1 shows the DNA band of a positive control, lane 2 shows no DNA band of a negative control, lanes 3 and 4 shows the 16S rDNA bands of isolate 14 and lane 5 shows a 1 kb plus ladder.

1            2            3            4            5

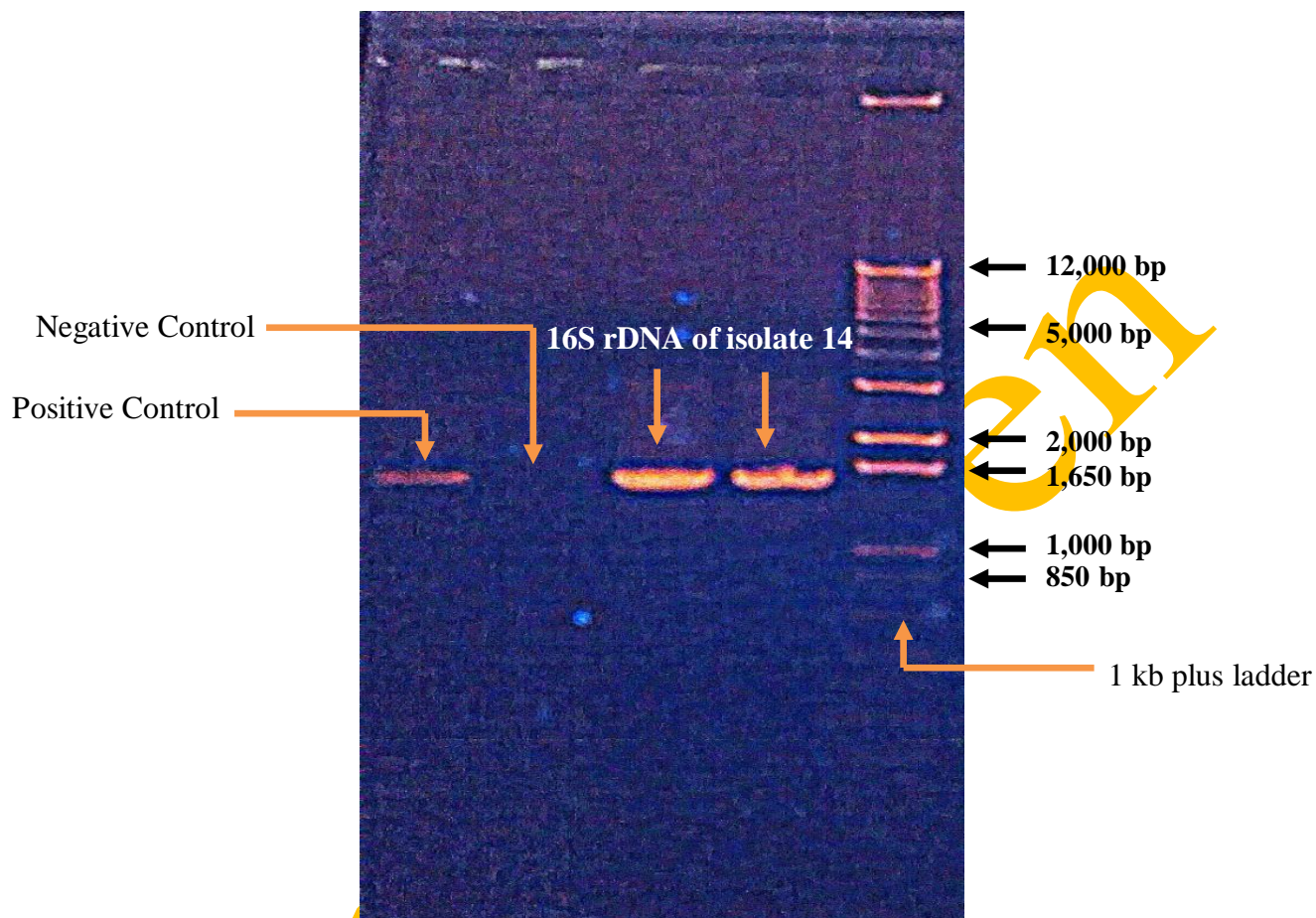

**Figure 3.12:** Visible DNA bands over UV illuminator on 1% agarose gel after electrophoresis. It can be seen that the 16S rDNA bands of isolate 14 which migrated along the lanes of wells 3 and 4 are slightly lower than 1,650 bp when compared to the ladder which migrated along the lane of well 5. Lane 1 indicates the DNA band of positive control and lane 4 shows that no band can be seen for the negative control.

### 3.8. DNA sequencing

Prior to sequencing, the purity and concentration of the DNA sample was measured using NanoDrop 200 spectrophotometer. It was observed that the purity of the sample had a purity ratio of 1.9 (OD 260 / OD 280) and a concentration of 113 ng/μl.

### 3.9. Bioinformatics analysis to identify the bacteria

The trimmed and corrected 16S rRNA gene sequence of isolate 14 was added to NCBI Nucleotide BLAST website and a list of 100 sequences which were most similar to the query sequence was obtained. All bacteria listed in the table were from the genus '*Bacillus*' which confirmed that

isolate 14 is from the '*Bacillus*' genus. Table 3.4 represents the query sequence (that is rDNA gene sequence of isolate 14). Table 3.5 illustrates the first 10 similar bacterial sequences from the table. From the phylogenetic tree in Figure 3.13 it was observed that the query sequence shares the same node with a strain of *Bacillus cereus* and the bootstrap value is 70% which confirms that isolate 14 is a strain of *Bacillus cereus*.

ScholarlyPen

**Table 3.4: Trimmed and corrected 16S rRNA gene sequence of isolate 14 (FASTA format)**

Sequence name	16S rRNA gene sequence of isolate 14
EMBOSS 001	<pre> &gt;EMBOSS_001 TGCAGTCGAGCGAATGGATTAAGAGCTTGCTCTTATGAAAGTTAGCGGCGGACGGGTGAGTAACACGTG GGTAACCTGCCATAAGACTGGGATAACTCCGGGAAACCGGGGCTAATACCGGATAACATTTTGAACC GCATGGTTCGAAATTGAAAGGCGGCTTCGGCTGTCACTTATGGATGGACCCGCGTCGCATTAGCTAGTT GGTGAGGTAACGGCTCACCAAGGCAACGATGCGTAGCCGACCTGAGAGGGTGATCGGCCACACTGGGA CTGAGACACGGCCCAGATTCTACGGGAGGCAGCAGTAGGGAATCTTCCGCAATGGACGAAAGTCTGA CGGAGCAACGCCGCGTGAGTGATGAAGGCTTTCGGGTCGTAAAACCTCTGTTGTTAGGGAAGAACAAGT GCTAGTTGAATAAGCTGGCACCTTGACGGTACCTAACCAGAAAGCCACGGCTAACTACGTGCCAGCAG CCGCGGTAATACGTAGGTGGCAAGCGTTATCCGGAATTATTGGGCGTAAAGCGCGCGCAGGTGGTTTCT TAAGTCTGATGTGAAAGCCCACGGCTCAACCGTGGAGGGTCATTGGAAACTGGGAGACTTGAGTGCAG AAGAGGAAAGTGGAATTCATGTGTAGCGGTGAAATGCGTAGAGATATGGAGGAACACCAGTGGCGA AGGCGACTTTCTGGTCTGTAAGTACTGACACTGAGGCGCGAAAGCGTGGGGAGCAAACAGGATTAGATACC CTGGTAGTCCACGCCGTAACGATGAGTGCTAAGTGTTAGAGGGTTCGCGCCCTTAGTGCTGAAGTTA ACGCATTAAGCACTCCGCCTGGGGAGTACGGCCGCAAGGCTGAAACTCAAAGGAATTGACGGGGGCC GCACAAGCGGTGGAGCATGTGGTTTAATTCGAAGCAACGCGAAGAACCTTACCAGGTCTTGACATCCT CTGAAAACCCTAGAGATAGGGCTTCTCCTTCGGGAGCAGAGTGACAGGTGGTGCATGGTTGTCGTCAG CTCGTGTCGTGAGATGTTGGGTTAAGTCCCAGAACGAGCGCAACCCTTGATCTTAGTTGCCATCATTAA GTTGGGCACTCTAAAGGTGACTGCCCCGGTGACAAACCGAAGGAAGGTGGGGATGACGTCAAATCATCA GGCCCCTTATGACCTGGGCTACACACGTGCTACAATGGACGGTACAAAGAGCTGCAAGACCGCGAGGT GGAGCTAATCTCATAAAACCGTTCTCAGTTCGGATTGTAGGCTGCAACTCGCCTACATGAAGCTGGAAT CGCTAGTAATCGCGGATCAGCATGCCGCGGTGAATACGTTCCCAGGGCCTTGTACACACCGCCCGTCACA CCACGAGAGTTTGTAAACACCCGAAGTCGGTGGGG                     </pre>

**Table 3.5: Top 10 similar sequences compared to the 16S rRNA sequence of isolate 14 acquired from NCBI nucleotide BLAST**

Sl. No.	Description	Max score	Total score	Query cover	E value	Identity	Accession
1	<i>Bacillus cereus</i> ATCC 14579 16S ribosomal RNA(rrna) gene, complete sequence	2475	2475	99%	0.0	99%	NR_074540.1
2	<i>Bacillus cereus</i> strain JCM 2152 16S ribosomal RNA gene, partial sequence	2475	2475	99%	0.0	99%	NR_113266.1
3	<i>Bacillus cereus</i> strain CCM 2010 16S ribosomal RNA gene, complete sequence	2475	2475	99%	0.0	99%	NR_115714.1
4	<i>Bacillus cereus</i> strain NBRC 15305 16S ribosomal RNA gene, partial sequence	2475	2475	99%	0.0	99%	NR_112630.1
5	<i>Bacillus cereus</i> strain ATCC 14579 16S ribosomal RNA gene, partial sequence	2475	2475	99%	0.0	99%	NR_114582.1
6	<i>Bacillus cereus</i> strain IAM 12605 16S ribosomal RNA gene, partial sequence	2475	2475	99%	0.0	99%	NR_115526.1
7	<i>Bacillus anthracis</i> str. Ames 16S ribosomal RNA gene, complete sequence	2466	2466	99%	0.0	99%	NR_074453.1
8	<i>Bacillus toyonensis</i> strain BCT-7112 16S ribosomal RNA gene, complete sequence	2457	2457	99%	0.0	99%	NR_121761.1
9	<i>Bacillus thuringiensis</i> strain ATCC 10792 16S ribosomal RNA gene, partial sequence	2547	2547	99%	0.0	99%	NR_114581.1
10	<i>Bacillus thuringiensis</i> strain IAM 12077 16S ribosomal RNA gene, partial sequence	2547	2547	99%	0.0	99%	NR_043403.1

The evolutionary history was inferred by using the Maximum Likelihood method based on the Tamura-Nei model with 500 bootstrap replications (Tamura and Nei, 1993). The tree with the highest log likelihood (-3600.5734) is shown. The percentage of trees in which the associated taxa clustered together is shown next to the branches. Initial tree(s) for the heuristic search were obtained by applying the BioNJ method to a matrix of pairwise distances estimated using the Maximum Composite Likelihood (MCL) approach. The tree is drawn to scale, with branch lengths measured in the number of substitutions per site. The analysis involved 13 nucleotide sequences. All positions containing gaps and missing data were eliminated. There were a total of 1214 positions in the final dataset. Evolutionary analyses were conducted in MEGA6 (Tamura *et al.*, 2013).

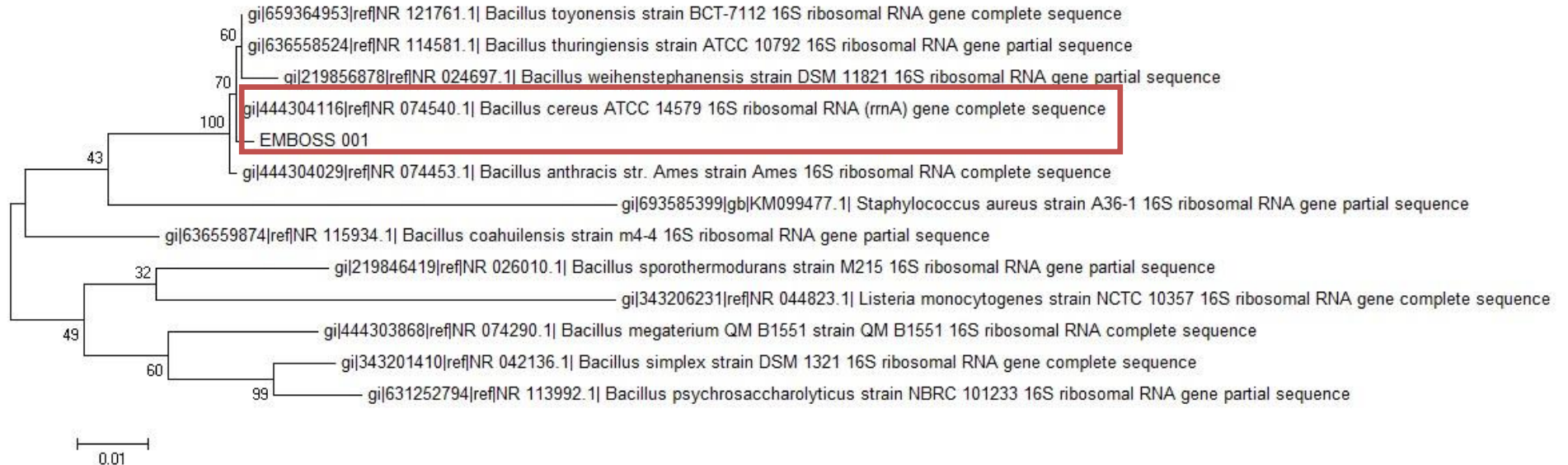

**Figure 3.13: Molecular Phylogenetic analysis by Maximum Likelihood method. The query sequence in this tree is subjected as 'EMBOSS 001'. It can be observed that the query sequence shares the same node with *Bacillus cereus* ATCC 14579 16S ribosomal RNA (rrna) gene complete sequence and the bootstrap value is 70. This confirms that isolate 14 is a strain of *Bacillus cereus*.**

ScholarlyPen

### 3.10. Characterization of amylase enzyme

#### 3.10.1. Effect of temperature

The enzyme had a low activity from 25°C until 55 °C. At 65°C there was a boost in the activity and it increased even further at 75°C (Figure 3.14). The greatest activity of the enzyme was observed at 75°C. This was considered to be the optimum temperature of the enzyme. The activity was seen to decrease at 85°C.

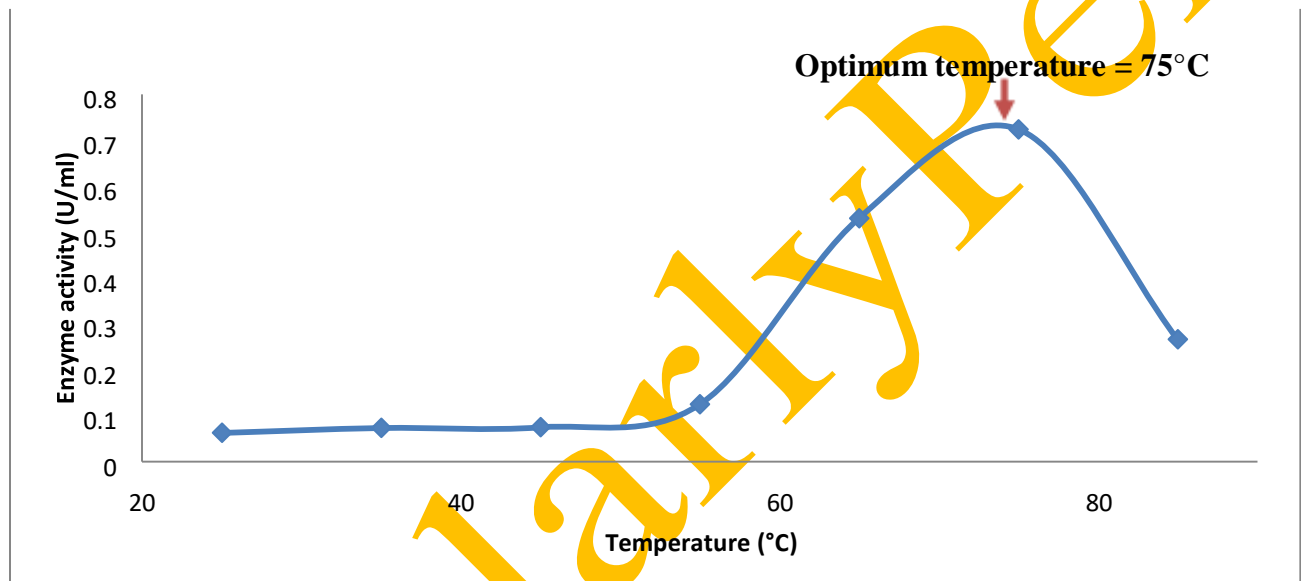

**Figure 3.14: Effect of temperature on the activity of crude amylase of isolate 14**

#### 3.10.2. Effect of pH

The activity of the enzyme was fairly moderate at pH 3. With an increase in pH, the activity of the enzyme was observed to increase as well. There a boost in activity from pH 6 pH 7. However, the enzyme activity decreased from pH 8 to 10. pH 7 is considered to be the optimum pH for this amylase enzyme (Figure3.15).

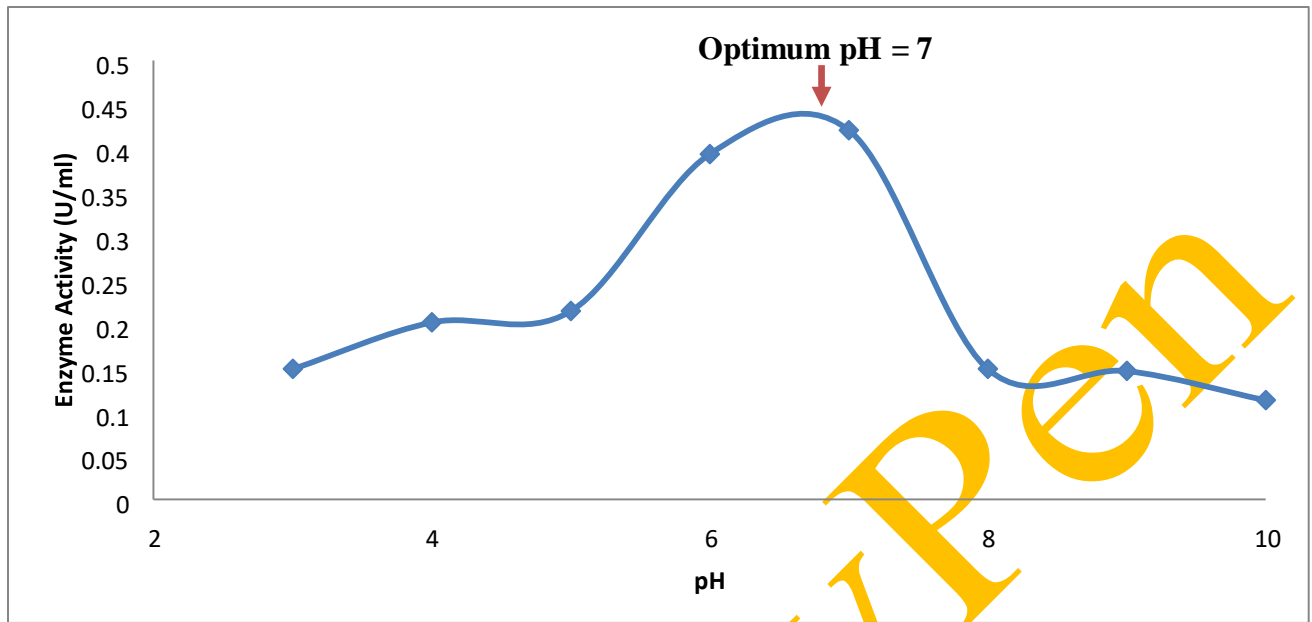

**Figure 3.15: Effect of pH on the activity of crude amylase of isolate 14**

ScholarlyPen

*Chapter 4*

# DISCUSSION

## Discussion

Enzymes are not only essential for carrying out biochemical reactions within an organism, but their high specificity and catalytic characteristics have enabled them to be used in various industrial sectors for the production of a wide range of products. Amylase is one of those enzymes. Globally, amylase is being frequently used in food, textile, detergents and paper industries. In addition, pharmaceutical and chemical industries use amylase on a regular basis to yield their products (El-Fallal *et al.*, 2012). Amylase is extensively used in Bangladesh in garments and textile industries along with industries that manufacture food and pharmaceuticals products (Islam *et al.*, 2014). However, there is no local production of commercial amylase in the country and thus a lot of money is spent on the process of enzyme import. Harmful chemicals are also used as an alternative to amylase (Dash *et al.*, 2015). For this reason, it is necessary that a process is established to generate commercial amylase in the country.

Since industrial amylase is usually extracted from bacteria and fungi, it is mandatory to isolate a local high amylase producing strain. In this study, the main aim was to isolate an amylase producing bacterial strain from soil and identify the strain via presumptive and genotypic methods. The study also included characterization of the produced amylase enzyme by determining the optimum temperature and pH at which the enzyme works best.

Due to the availability of various types of bacteria in soil, it was chosen as the source of bacterial isolation. The soil collected for this study was from a dairy farm in Keraniganj, which had decayed

cow manure mixed with it. In primary screening of the bacterial strains, it was observed that 17 out of 48 isolates were amylase producers. This was determined by growing the isolates on starch agar medium and detecting any clear zone production around the bacterial colonies by adding Gram's iodine. The clear zones produced were due to the absence of starch which was hydrolyzed by the amylase enzyme excreted by the bacteria. The number of amylase producing bacteria obtained from this type of soil sample was quite low. In a study by Peltier and Beckord (1945), 17 isolates from soil and 26 isolates from compost were obtained which produced amylase. The number of isolates is similar to that found in this study, although the sample used here was a mixture of the two separate samples mentioned in the article and hence was expected to have a larger load of amylase producing bacteria although only 36% of the bacteria were as such. A reason behind this might be due to the extensive dilution of the sample during sample processing and thus many bacterial isolates were lost in the process. A better source of amylase producing bacteria is soil from potato fields and kitchen waste dump sites (Peltier and Beckord, 1945). Among the bacteria obtained, two isolates with the largest ratio of clear zone were chosen.

In order to determine the amount of amylase produced by the selected isolates, enzyme assay was carried out. This was done using the method that involved the use of 3, 5 – dinitrocelisalisylic acid (DNS). This is one of the simplest and most widely used methods to determine the amount of reducing sugar produced and hence is an indication of the enzyme activity (El-Fallal *et al.*, 2012). Amylase produces reducing sugar by breaking down starch into glucose. So a greater concentration of glucose indicates a greater level of starch break down and hence a higher activity of amylase. It was observed that isolate 14 showed an activity of 0.123 U/ml while isolate 28 showed an activity of 0.076 U/ml. In a study by Vaseekaran *et al* (2010) the amylase activity of three isolates were found to be within the range from 5 to 8 U/ml. This is a much greater find compared to that found in this study. This might be because the optimum fermentation conditions of isolates 14 and 28 were not known as they were unknown bacterial isolates. The first isolate had a greater activity than the other one and hence it was chosen as the final bacteria to be worked with throughout the study. In order to determine the specific activity of the two isolate, the Folin-Lowry method for total protein estimation was carried out. The specific activity of isolate 14 was 0.173 U/mg while for isolate 28 it was 0.128 U/mg. Isolate 14 showed a greater level of activity than isolate 28.

The next steps of the study were based on the identification of the bacterial strain. It is important to identify a bacterial species due to various reasons. For instance, unknown bacteria can be given a name by comparing it with a known bacterium and hence can be placed in a taxonomic class (Steel, 1965). Also, identifying a bacterial strain leads to the development and optimization of the media according to the organism. In addition, the strain can be improved through site directed mutation if there is prior knowledge about the bacteria genetic make up. Most importantly, knowing how a bacteria works and how it is structured means knowing how it might affect humans (Katzung, 2004). In order to identify a bacterial strain properly, verification should involve biochemical and other phenotypic criteria as well as DNA relatedness (Baron, 1996).

At first, the strain underwent physical identifications. Through Gram staining it was observed that the bacterial strain was Gram positive, rod shaped and arranged singly or two bacterial cells in chains. Microscopic observation also revealed the presence of spores in the bacteria after spore staining. The bacterial strain was also scrutinized by observing the colony morphology. This included the physical appearance of the bacterial colonies on nutrient agar medium. This medium was selected because it is a non selective and non differentiating medium which allows the growth of maximum types of bacterial strains and due to the absence of any selective components in the medium, the appearance of the bacterial colonies are not affected. Various biochemical tests were performed to verify the biochemical characteristics of the bacterial isolate through which it was determined that apart from amylase, this bacterial isolate can also produce the enzymes catalase, urease, cellulase, gelatinase, nitrate reductase and casease but not oxidase. In addition, it was observed that isolate 14 does not carry out mixed acid and 2,3- butanediol fermentation, can convert tryptophan to indole and break down blood cells via  $\beta$  hemolysis. Moreover, the sugars that isolate 14 was observed to be able to ferment are glucose, maltose, sucrose, glycerol and fructose but not xylose, mannitol and citrate. Also, isolate 14 has been identified as non motile, facultative anaerobic, mesophilic, intolerant to excessive salt concentration and non hydrogen sulphide or any other gas producing bacteria.

In order to recognize the bacteria further, identification on the genetic level was performed. This was done through the process of 16S rRNA gene sequencing. This gene is a part of the prokaryotic DNA and has been the most common housekeeping genetic marker in order to study the phylogeny

and taxonomy of a bacterial strain. This is because (i) it is present in almost all bacteria and might often exist as a multigene family, or operons; (ii) over time, there has been no change seen in the function of the 16S rRNA gene and hence any change in the sequence indicates a more accurate measure of time (evolution); (iii) the size of the gene is large enough to be used for informative purposes (1500 bp) (Patel, 2001). The initial step of the process was DNA extraction. This was done using the Wizard® Genome DNA Purification Kit. The DNA acquired was the total genome DNA of the bacteria. From there, the 16S rRNA gene containing DNA was specifically amplified using selective universal primers: 27F forward and 1492R reverse primers. These primers are designed to have base sequences complementary to the sequences of the 16S rRNA gene and hence attach to the area where the gene is located to perform replication. The same primers were used in the study conducted by Elijah *et al* (2014) for the identification of an unknown bacterial strain associated with cassava waste. The amplification was done using the Polymerase Chain Reaction method. Afterwards, the 16S rRNA gene amplification was checked using agarose gel electrophoresis. As expected, the acquired 16S rRNA DNA band was observed to have a size of less than 1,650 bp. The PCR amplicon was further purified to extract the DNA. This was done using the Wizard® SV Gel and PCR Clean-Up System in order to purify the DNA for sequencing purposes. Purity of the DNA sample is necessary and hence it was checked prior sequencing. This was done using a NanoDrop 2000 spectrophotometer. The DNA sample was observed to have an appropriate purity and concentration needed for sequencing purposes. The entire sequencing process was carried out using the Sanger method in the '1<sup>st</sup> BASE' Laboratories in Malaysia. The results were received within 1 week. The traces of the DNA sequences were then opened using Mega6 software. However, it is necessary to clean the DNA sequence by eliminating and replacing improper bases as errors occur in the method. Thus, the sequence was trimmed to eliminate the faulty bases and cleaned manually using Lasergene Seqman software. In order to identify the bacteria, the corrected genetic sequence was added to NCBI nucleotide BLAST database website which comprises of a massive collection of most of the genetic sequences of different organisms. Using NCBI nucleotide BLAST, it was observed that the first 100 16S rRNA sequences that were seen to be between 93% to 99% identical to that of isolate 14 were from the genus '*Bacillus*'. The result was expected as most of the amylase producing bacteria from soil has been identified as *Bacillus* in various studies. However, in order to identify the species of *Bacillus*, it was necessary to create a phylogenetic tree. Different species of *Bacillus* was taken from the table acquired from

NCBI BLAST along with some bacterial species which are divergent to the bacteria. From the phylogenetic tree it was confirmed that the species of this *Bacillus* bacteria belonged to the *Bacillus cereus* group. This is because the node of isolate 14 and a species of *Bacillus cereus* was common and the stability of the node was seen to be over 50% which is acceptable (Thomas, 2014).

The identification was further strengthened by checking the results of the colony morphology of isolate 14 with that of *Bacillus cereus*. According to Logan and Vos (1872) and Frankland and Frankland (1877), the colonies of *Bacillus cereus* are large, vary in shape from circular to regular, matt or granular in texture, have entire to undulate, crenate or fimbriate edges and are whitish to cream in colour. When compared to the results of colony morphology of isolate 14, the description of the colony appearance was similar to that of *Bacillus cereus*. When the biochemical profile was compared between isolate 14 and *Bacillus cereus*, most of the results were observed to be similar except some. For instance, *Bacillus cereus* is usually motile, Voges–Proskauer-positive, indole negative and can utilize citrate (Frankland and Frankland, 1877). For isolate 14, however, these tests showed opposite results. A result like this, although unexpected, might be possible. For instance, it was observed in a study that out of 461 strains of *Bacillus cereus*, 97.9% were motile, 93.1% could utilize citrate and 98.6% were Voges–Proskauer positive (Wong, n.d.). So, although maximum strains demonstrated a positive result, it was not 100% positive. Also, the results of citrate utilization may vary according to the test method used (Logan and Vos, 1872). However, for indole production in that study, the positivity of the result was 0% (Wong, n.d.). The unexpected result of indole test for this bacterial isolate might be due to the presence of contaminants which provoked a false positive result. Another reason might be environmental stress or slight evolutionary changes which led to isolate 14 show different results in these tests. Phenotypic properties have been observed to be unstable at times and the expression can be dependent upon changes in environmental conditions such as growth substrates, temperature and pH levels (Rossello-Mora and Aman, 2001). Difference in strains is also known to provoke variable results in biochemical tests. However, since out of all the tests performed, 80% results of the biochemical profile along with the results of the colony morphology are exactly similar to that of *Bacillus cereus*, it can be said that isolate 14 is a strain of *Bacillus cereus*.

The second part of the study was based on the characterization of the amylase enzyme generated by this strain of *Bacillus cereus*. The rate at which starch is broken down by amylase depends on various parameters (Sivaramakrishnan *et al.*, 2006). Characterizing an enzyme leads to the determination of optimum fermentation conditions for that enzyme. Moreover, the inhibitory concentrations of salts and metal ions for that particular enzyme can be checked. The properties of amylase should meet its application and hence it is mandatory to check its optimum conditions which can be done via characterization (Sivaramakrishnan *et al.*, 2006). Some of the most important ones include optimum temperature and pH. Hence, the enzyme was characterized by carrying out enzyme assay at different temperatures and pH in order to detect the optimum conditions. There are various ways to characterize an enzyme. In this study, the DNS method was used which determines the amount of reducing sugar produced at different temperatures and pH by the enzyme.

It was detected that the activity of amylase was low at temperatures from 25°C to 45°C. However, a drastic elevation of activity was observed from 55°C which maximized at 75°C. At a higher temperature of 85°C, the activity started to recede. So, this particular amylase showed highest activity at 75°C. Thus it can be concluded that the amylase is most active at a moderately high temperature as compared to amylases worked with on different studies. In a study conducted by Cordeiro *et al* (2002) who worked with a thermophilic *Bacillus* sp. strain SMIA-2 isolated from the soil of Brazil produced amylase with an optimum temperature of 70°C. In a study by Kim *et al* (1995) the optimum temperature of the amylase was observed to be 60°C produced by the *Bacillus* Strain, GM890 and in a study by Fattah *et al* (2013) where the amylase produced from *Bacillus licheniformis* Isolate AI20 showed the highest activity between the range of 60-80°C. In another study, it was observed that the strain *Bacillus* sp. WA21 produced amylase enzyme which had a lower optimum temperature of 55°C (Asad *et al.*, 2011).

When the enzyme was characterized to identify optimum pH, it was observed that the amylase showed the highest activity at pH 7. From pH 3 to pH 5 the activity was moderate and gradually increasing but at pH 6 it elevated drastically up to pH 7. However, the enzyme started showing lower activity as the pH moved to the alkaline range from 8 to 10. From this result, it can be concluded that the enzyme works best at a neutral pH. The result correlates completely with the

optimum pH found in the studies by Vaidya and Rathore (2015) who isolated the *Bacillus* strain APIB2 from a potato dump site in Madhya Pradesh, India and Vasekaran *et al* (2010) who identified their strain as *Bacillus licheniformis*. Another research revealed the optimum pH of amylase produced by *Bacillus licheniformis* Isolate AI20 was within the range of 6 to 7.5 which is similar to that found in this study (Fattah *et al.*, 2013). The optimum pH was detected to be 7.5 in a study performed by Cordiero *et al* (2002) who worked with the *Bacillus* sp. strain SMIA2. On the other hand, Asad *et al* (2011) analysed that for the bacterial strain *Bacillus* SP. WA21 the optimum pH of the amylase obtained was 6 which is less than that found in this study. A higher optimum pH of amylase was obtained within the range of pH 10.5 to 12 in an investigation by Kim *et al* (1995) who worked with the *Bacillus* Strain, GM890.

Overall, it can be comprehended that it is not uncommon for amylase to work best at a high temperature and neutral pH as supported by the results of the cited articles and of this research work. In order to be effective in industrial processes, it is necessary for an enzyme to work at high temperatures (Sivaramakrishnan *et al.*, 2006). Since the amylase enzyme concerned with in this study works best at 75°C, it can be postulated that this temperature is fairly high to carry out different processes such as starch liquefaction which is generally carried out at higher temperatures of 70–90 °C (Soni *et al.*, 2003). The temperature is, on the other hand, not too high that a large amount of energy will be needed to heat up the fermenters. Also, since the optimum pH for this amylase is 7, a neutral condition is appropriate for the enzyme to work best which may prevent the need to make the fermentation condition too alkaline or acidic for the enzyme to work. However, many fermentation processes release acids and hence pH of the medium need to be controlled in that case.

Studies similar to this are essential for the initiation of commercial amylase production in Bangladesh. However, further research work is necessary. For instance, the enzyme is advised to be extensively characterized further to determine the thermostability, pH stability, effect of different metal ions and different substrates. Also, the bacterial isolate itself can be characterized and the optimum fermentation conditions can be determined. Moreover, genetic modification can be done for the improvement of the strain, the crude amylase can be purified and also the encoded sequence of amylase can be determined. With all these information in hand, in the near future it is

hoped that the demand of commercial amylase in Bangladeshi industries will be fulfilled. Also, new industries can be established with a sole focus on the commercial production of amylase which is hoped to overthrow the need of expensive commercial amylase import processes and use of harmful chemicals. Instead, it is anticipated that Bangladesh will soon be able to export amylase to other countries and help elevate the economic condition of the country.

## References

Amira El-Fallal, M. A.-S. (2012). Starch and Microbial  $\alpha$ -Amylases: From Concepts to Biotechnological Applications. In C.-F. Chang, *Carbohydrates - Comprehensive Studies on Glycobiology and Glycotechnology* (pp. 459-476). CC BY 3.0 licence .

Arvinder Kaur, Manjeet Kaur, Manohar Lal Samyal, Zabeer Ahmed. (2012). Isolation, characterization and identification of bacterial strain. *Journal of Microbiology and Biotechnology Research* , 573-579.

Baron, E. J. (1996). Classification. In S. Baron, *Medical Microbiology*. Texas: University of Texas Medical Branch at Galveston.

Carlos Alberto Martins Cordeiro, M. L. (2002). PRODUCTION AND PROPERTIES OF  $\alpha$ -AMYLASE FROM THERMOPHILIC BACILLUS SP. *Brazilian Journal of Microbiology* , 57-61.

D. E. Koshland, J. (1963). Correlation of Structure and Function of Enzyme Action. *Science* , 142 (3599), 1533-1541.

Dipali Parmar, A. P. (2012). Characterization of Amylase Producing Bacterial Isolates. *Bulletin of Environment, Pharmacology and Life Sciences* , 1, 42-47.

Elijah A.I., A. O. (2014). Molecular Characterization and Potential of Bacterial Species Associated with Cassava Waste. *Nigerian Food Journal* , 32, 56-65.

GEORGE L. PELTIER, L. D. (1945). SOURCES OF AMYLASE-PRODUCING BACTERIA. 711-714.

GHOSE, T. K. (1987). MEASUREMENT OF CELLULASE ACTIVITIES. *INTERNATIONAL UNION OF PURE AND APPLIED CHEMISTRY* , 59, 257-268.

Hannah Roy, Q. H. (n.d.). Role of Salivary Amylase in Digestion of food.

Held, P. (2012). *Enzymatic Digestion of Polysaccharides*. Retrieved from [www.biotek.com](http://www.biotek.com).

Inc., N. E. (2016). *PCR Protocol for Taq DNA Polymerase with Standard Taq Buffer (M0273)*. Retrieved from New England Biolabs Inc.: <https://www.neb.com/protocols/1/01/01/taq-dnapolymerase-with-standard-taq-buffer-m0273>

James. G. Cappuccino, N. S. (2005). Gram Stain. In N. S. James. G. Cappuccino, *Microbiology: A Laboratory Manual* (pp. 71-76). Pearson Education India.

James.G.Cappuccino, N. S. (2005). Differential Staining for Visualization of Bacterial Cell Structures. In N. S. James.G.Cappuccino, *Microbiology: A Laboratory Manual* (pp. 83-85). Pearson Education India.

Katzung, B.G. (2004). *Basic and Clinical Pharmacology* (9th Ed.). Lange Medical Books/McGraw-Hill, New York City.

Leszczyński, W. (2004). RESISTANT STARCH – CLASSIFICATION, STRUCTURE, PRODUCTION. *POLISH JOURNAL OF FOOD AND NUTRITION SCIENCES* , 13/54, 37-50.

M.S.Islam, M. B. (2014). Determination of alpha-amylase activity of *Streptomyces* spp isolated from Bangladeshi soils. *International Journal of Interdisciplinary and Multidisciplinary Studies* , 1, 167-170.

Mojsov, D. K. (2012). MICROBIAL  $\alpha$ -AMYLASES AND THEIR INDUSTRIAL APPLICATIONS: A REVIEW. *International Journal of Management, IT and Engineering* , 583-609.

Muhammad Irfan, A. S. (2012). Isolation and screening of cellulolytic bacteria from soil and optimization of cellulase production and activity. *Turkish Journal of Biochemistry* , 287-293.

Neelam Gurung, S. R. (2012). A Broader View: Microbial Enzymes and Their Relevance in. *BioMed Research International* , 1-18.

Niall A. Logan, P. D. (1872). Genus I. Bacillus. In W. B. Whitman, *Bergey's Manual of Systemic Bacteriology* (Vols. 3, The Firmicutes, p. 21). USA: Springer Science+Business Media.

Nurullah AKCAN, F. U. (2011). Alpha-Amylase Production by *Bacillus subtilis* RSKK96 in Submerged Cultivation. S17-S22.

Publication, W. (1972). *Manual of Clinical Enzyme Measurements*. Freehold, NJ: Worthington Biochemical Corporation .

Rani Gupta, P. G. (2003). Microbial  $\alpha$ -amylases: a biotechnological perspective. *Process Biochemistry* , 1-18.

Rosselló-Mora, R., and R. Amann. (2001). The species concept for prokaryotes. *FEMS Microbiol. Lett.* 25:39-67.

S.K Soni, A. Kaur, J.K Gupta. (2003). A solid state fermentation based bacterial  $\alpha$ -amylase and fungal glucoamylase system and its suitability for the hydrolysis of wheat starch. *Process Biochem.* 39 (2003) 185–192.

S. Vasekaran, S. B. (2010). Isolation and Identification of a Bacterial Strain Producing. *Tropical Agricultural Research* , 22(1), 1-11.

Soumya Vaidya, P. R. (2015). ISOLATION, SCREENING AND CHARACTERIZATION OF AMYLASE PRODUCING BACTERIA FROM SOIL OF POTATO DUMP SITES FROM DIFFERENT REGIONS OF MADHYA PRADESH. *Sanghvi Institute of Management and Science*. Indore: ResearchGate.

*Standard Nucleotide BLAST*. (n.d.). Retrieved from National Centre of Biotechnology Information (NCBI): [https://blast.ncbi.nlm.nih.gov/Blast.cgi?PAGE\\_TYPE=BlastSearch](https://blast.ncbi.nlm.nih.gov/Blast.cgi?PAGE_TYPE=BlastSearch)

Sundarram, A. , & Murthy, T. P. K. (2014).  $\alpha$ -Amylase Production and Applications: A Review. *Journal of Applied & Environmental Microbiology*, 2(4), 166-175

TAE UN KIM, B. G. (1995). Purification and Characterization of a Maltotetraose-Forming Alkaline  $\alpha$ -Amylase from an Alkalophilic *Bacillus* Strain, GM8901. *APPLIED AND ENVIRONMENTAL MICROBIOLOGY* , 61, 3105–3112.

Tamura K. and Nei M. (1993). Estimation of the number of nucleotide substitutions in the control region of mitochondrial DNA in humans and chimpanzees. *Molecular Biology and Evolution* 10:512-526.

Tamura K., Stecher G., Peterson D., Filipski A., and Kumar S. (2013). MEGA6: Molecular Evolutionary Genetics Analysis version 6.0. *Molecular Biology and Evolution* 30: 2725-2729.

Thomas, K. (2014). *How to Build Your Own Phylo Trees with Mega6*. Retrieved from blogorrhea:<http://asserttrue.blogspot.com/2014/05/how-to-build-your-own-phylo-trees-with.html>

WAJEEHA ASAD, M. A. (2011). EXTRACELLULAR ENZYME PRODUCTION BY INDIGENOUS THERMOPHILIC BACTERIA: PARTIAL PURIFICATION AND CHARACTERIZATION OF  $\alpha$ -AMYLASE BY BACILLUS SP. WA21. *Pakistan Journal of Botany* , 1045-1052.

Wong H. (n.d.). BACILLUS CEREUS., Department of Microbiology. Soochow Univeristy.

Y.C. Ho, K. S. (2012). Industrial Discharge and Their Effect to the Environment. In P. K.-Y. Show, *Industrial Waste* (p. March). InTech.

Yasser R. Abdel-Fattah, N. A.-T.-G. (2013). Production, Purification, and Characterization of Thermostable  $\alpha$ -Amylase Produced by *Bacillus licheniformis* Isolate AI20. *Journal of Chemistry* , 2013, 1-11.

Zhang Z., Schawrtz S., Wanger L., Miller W. (2000). A greedy algorithm fro aligning DNA sequences. *J Comput Biol* 2000, 7(1-2):203-14.

## Appendix- I

### Media compositions

The composition of all media used in the study is given below.

#### **Nutrient Agar**

<b>Component</b>	<b>Amount (g/L)</b>
Peptone	5.0
Sodium chloride	5.0
Beef extract	3.0
Agar	15.0
Final pH	7.0

#### **Luria Bertani Broth**

<b>Component</b>	<b>Amount (g/L)</b>
Tryptone	10.0
Yeast extract	5.0
Sodium chloride	10.0

#### **Starch Agar**

<b>Component</b>	<b>Amount (g/ L)</b>
Beef extract	3.0
Soluble starch	10.0
Agar	12.0

#### **Simmon's Citrate Agar**

<b>Component</b>	<b>Amount (g/L)</b>
Magnesium sulphate	0.2
Ammonium dihydrogen phosphate	1.0
Dipotassium phosphate	1.0
Sodium citrate	2.0

Sodium chloride	5.0
Bacto agar	15.0
Bacto bromo thymol blue	0.08

#### Peptone Water

Component	Amount (g/L)
Peptone	10.0
Sodium chloride	5.0

#### Methyl red Vogus Prekaure (MRVP) Media

Component	Amount (g/L)
Peptone	7.0
Dextrose	5.0
Dipotassium hydrogen phosphate	5.0
Final pH	7.0

#### Triple Sugar Iron Agar

Component	Amount (g/L)
Bio-polytone	20.0
Sodium chloride	5.0
Lactose	10.0
Sucrose	10.0
Dextrose	1.0
Ferrous ammonium sulphate	0.2
Sodium thiosulphate	0.2
Phenol red	0.0125
Agar	13.0
Final pH	7.3

#### Motility Indole Urease (MIU) Agar

Component	Amount (g/L)
Tryptone	10
Phenol red	0.1
Agar	2.0
Sodium chloride	5.0
pH (at 25°C)	6.8 ± at 25°C

**Gelatin Broth**

Component	Amount (g/L)
Peptone	5.0
Beef extract	3.0
Gelatin	120.0
Final pH	6.8 ± 0.2 at 25°C

**Nitrate Reduction Broth**

Component	Amount (g/L)
Beef extract	3.0
Gelatin peptone	5.0
Potassium nitrate	1.0

**Mannitol Salt Agar**

Component	Amount (g/L)
Proteose peptone	10.0
Beef extract	1.0
Sodium chloride	75.0
D-mannitol	10.0
Phenol red	0.025
Agar	15.0
Final pH	7.4 ± 0.2 at 25°C

**Carboxymethylcellulose (CMC) Media**

Component	Amount (g/L)
Peptone	10.0
Carboxymethylcellulose	10.0
Dipotassium phosphate	2.0
Agar	10.0
Magnesium sulphate heptahydrate	0.3
Ammonium sulphate	2.5
Gelatin	2.0

**Blood Agar Base**

Component	Amount (g/L)
Beef heart infusion from (beef extract)	500.0
Tryptose	10.0
Sodium chloride	5.0

Agar	15.0
Final pH	6.8 ± 0.2 at 25°C

### Sugar Fermentation Broth

Component	Amount (g/L)
Sugar	5.0
Trypticase	10.0
Sodium chloride	5.0
Phenol red	A very small amount until the broth turns red

Appendix – II

### Reagents and Buffers

### **Crystal Violet (100 ml)**

To 29 ml 95% ethyl alcohol, 2 g crystal violet was dissolved. To 80 ml distilled water, 0.8 g ammonium oxalate was dissolved. The two solutions were mixed to make the stain and stored in a reagent bottle at room temperature.

### **Safranin (100ml)**

To 10 ml 95% ethanol, 2.5 g safranin was dissolved. Distilled water was added to the solution to make a final volume of 100 ml. The final solution was stored in a reagent bottle at room temperature.

### **Malachite green (100 ml)**

To 20 ml distilled water, 5 g malachite green was dissolved in a beaker. The solution was transferred to a reagent bottle. The beaker was washed two times with 10 ml distilled water separately and a third time with 50 ml distilled water and the solution were transferred to the reagent bottle. The remaining malachite green in the beaker was washed a final time with 10 ml distilled water and added to the reagent bottle. The stain was stored at room temperature.

### **Gram's iodine (300 ml)**

To 300 ml distilled water, 1 g iodine and 2 g potassium iodide was added. The solution was mixed on a magnetic stirrer overnight and transferred to a reagent bottle and stored at room temperature.

### **3, 5-Dinitrosalicylic acid (100 ml)**

To make 100 ml DNS, 1 g of DNS was added to 50 ml distilled water. Then, 20 ml of 2 M NaOH was added along with 28.2 g of sodium potassium tartarate. The volume was adjusted to 100 ml by adding distilled water and mixed well. The solution was stored at room temperature in an amber bottle to prevent exposure to light.

### **Kovac's Reagent (150 ml)**

To a reagent bottle, 150 ml of reagent grade isoamyl alcohol, 10 g of pdimethylaminobenzaldehyde (DMAB) and 50 ml of HCl (concentrated) were added and mixed.

The reagent bottle was then covered with an aluminum foil to prevent exposure of reagent to light and stored at 4°C.

#### **Methyl Red (200 ml)**

In a reagent bottle, 1 g of methyl red powder was completely dissolved in 300 ml of ethanol (95%). 200 ml of distilled water was added to make 500 ml of a 0.05% (wt/vol) solution in 60% (vol/vol) ethanol and stored at 4°C.

#### **Barrit's Reagent A (100 ml)**

5% (wt/vol) a-naphthol was added to 100 ml absolute ethanol and stored in a reagent bottle at 4°C.

#### **Barrit's Reagent B (100 ml)**

40% (wt/vol) KOH was added to 100 ml distilled water and stored in a reagent bottle at 4°C.

#### **Oxidase Reagent (100 ml)**

To 100 ml distilled water, 1% tetra-methyl-*p*-phenylenediamine dihydrochloride was added and stored in a reagent bottle covered with aluminum foil at 4°C to prevent exposure to light. **Catalase**

#### **Reagent (20 ml 3% hydrogen peroxide)**

From a stock solution of 35 % hydrogen peroxide, 583 µl solutions was added to 19.417 ml distilled water and stored at 4°C in a reagent bottle.

#### **Urease Reagent (50 ml 40% urea solution)**

To 50 ml distilled water, 20 g pure urea powder was added. The solution was filtered through a HEPA filter and collected into a reagent bottle. The solution was stored at room temperature.

#### **Nitrate Reagent A (100 ml)**

5N acetic acid was prepared by adding 287 ml of glacial acetic acid (17.4N) to 713 ml of deionized water. In a reagent bottle, 0.6 g of N,N-Dimethyl- $\alpha$ -naphthylamine was added along with 100 ml of acetic acid (5N) and mixed until the colour of the solution turned light yellow.

The reagent was stored at 4°C.

### **Nitrate Reagent B (100 ml)**

In a reagent bottle, 0.8 g of sulfalnic acid was added along with 100 ml acetic acid (5N) to form a colourless solution and stored at 4°C.

### **Ethidium Bromide (100 ml)**

To 100 ml distilled water, 1 g ethidium bromide was mixed. The solution was carefully stored at room temperature.

### **Lysozyme solution (20 ml)**

To 20 ml of distilled water, 0.2 g of lysozyme powder was added and dissolved. The solution was stored at 4°C.

### **Tris Boric Acid EDTA (TBE) Buffer (500 ml)**

To 500 ml distilled water, 5.4 g Tris HCL powder and 2.75 g boric acid were dissolved. The pH of the buffer was adjusted to 8, autoclaved and stored at room temperature.

### **Folin reagent A (100 ml)**

50 ml of 2% sodium carbonate was mixed with 50 ml of 0.1 N NaOH solution (0.4 gm in 100 ml distilled water.)

### **Folin reagent B (10 ml)**

10 ml of 1.56% copper sulphate solution was mixed with 10 ml of 2.37% sodium potassium tartarate solution.

### **Folin reagent C (100 ml)**

The reagent was made by mixing 2 ml of reagent B with 100 ml of reagent B.

### **Folin - Ciocalteu reagent solution (1N, 4ml)**

The commercial reagent (2N) was diluted with an equal volume of water on the day of use (2 ml of commercial reagent + 2 ml distilled water). **Citrate Buffer (0.05 M 50 ml)**

To make 1 M 50 ml citrate buffer, 14 g citric acid was added to 50 ml distilled water. From there, 2.5 ml buffer was added to 47.5 ml distilled water to make 50 ml of 0.05 M buffer. The pH was adjusted to need (3,4,5) using NaOH and HCl. The buffer was autoclaved and stored at 4°C.

#### **Sodium Phosphate Buffer (0.05 M 50 ml)**

For 50 ml of 0.05 M  $\text{NaH}_2\text{PO}_4$ , 0.35 g was added to 50 ml distilled water. For 50 ml of 0.2 M  $\text{Na}_2\text{HPO}_4$ , 0.67 g was added to 50 ml distilled water. To make sodium phosphate buffer of pH 6, 1.28 ml of  $\text{Na}_2\text{HPO}_4$  was mixed with 3.73 ml  $\text{NaH}_2\text{PO}_4$  and the volume was adjusted to 50 ml using distilled water. For pH 7, 2.89 ml  $\text{Na}_2\text{HPO}_4$  was added to 2.12 ml  $\text{NaH}_2\text{PO}_4$  and the volume was adjusted to 50 ml by adding distilled water. The buffer was autoclaved and stores at 4°C.

#### **Tris – Hydrochloric Acid Buffer (0.05 M 50 ml)**

To 45 ml distilled water, 0.3941 g Tris-HCl was added and made upto 50 by adding sodium hydroxide. The buffer was autoclaved and stores at 4°C.

#### **Glycine – Sodium Hydroxide Buffer (0.05 M 50 ml)**

To 25 ml distilled water, 0.117 g glycine was added. To another 25 ml distilled water, 0.03g sodium hydroxide was added. The two solutions were mixed. The final solution was autoclaved at stored at 4°C.

### Appendix – III

#### **Instruments**

The instruments used in the study are given below.

<b>Instrument</b>	<b>Manufacturer</b>
Weighing Machine	Adam equipment, UK
Incubator	SAARC
Laminar Flow Hood	SAARC
Autoclave Machine	SAARC
Sterilizer	Labtech, Singapore

Shaking Incubator, Model: WIS-20R	Daihan Scientific Companies, Korea
Water Bath	Daihan Scientific Companies, Korea
Spectrophotometer, UV mini - 1240	Shimadzu Corporation, Australia
NanoDrop 2000 Spectrophotometer	Thermo Scientific, USA
Table Top Centrifuge	Digisystem, Taiwan
Microscope	A. Krüssoptronic, Germany
Agarose Gel Electrophoresis Apparatus	Cleaver Scientific Ltd, Denmark
PCR Machine, Model: 2720 Thermal Cycler	Applied Biosystems, Singapore
Power Supply Machine: Elite 300 plus	Wealtec Corp, USA
UV Transilluminator, Model: MD-20	Wealtec Corp, USA
-20°C Freezer	Siemens, Germany
Magnetic Stirrer, Model: JSHS-180	JSR, Korea
Vortex Machine	VWR International
Microwave Oven, Model:MH6548SR	LG, China
pH Meter: pHep Tester	Hanna Instruments, Romania
Microcentrifuge Machine: Minispin Plus	Eppendorf, Germany
Micropipette	Eppendorf, Germany
Disposable Micropipette tips	Eppendorf, Ireland
Microcentrifuge tubes	Tarsons Products, Pvt Ltd, Kolkata
ABI Genetic Analyzer, Model: 3700	Applied Biosystems, USA